

Order designation: Front bracket __x__ / Ø __
 Example: Front bracket 50 x 50 / Ø 45

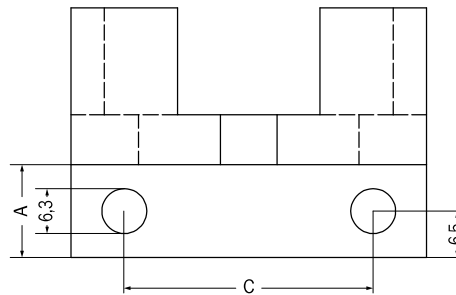

Installation examples

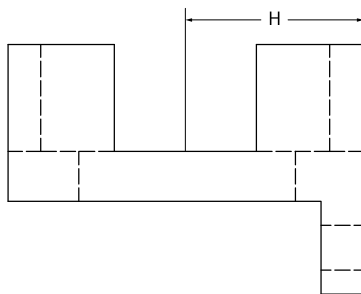
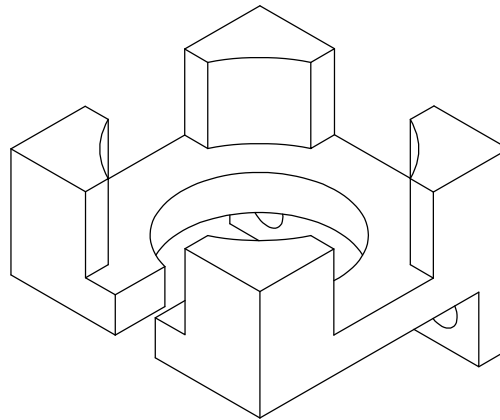
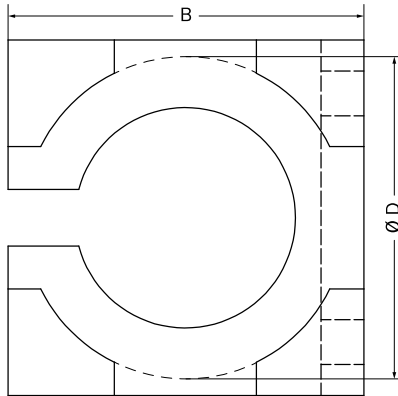
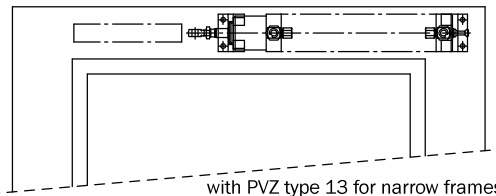
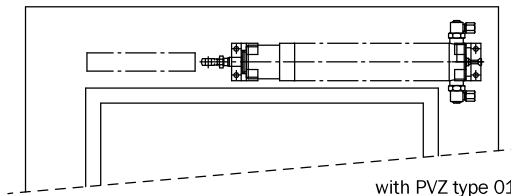

Every two front brackets are required for the rigid fixation of a cylinder, e.g. on a window pane. This way shear fixations can be actuated.

Short description

Technical data

Order designation: Front bracket	Cylinder PZ or PVZ 32 / 40			Cylinder PZ or PVZ 50	
	Please take into account the distinct head and base diameters!			60x60 / Ø 60	
	50x50 / Ø 40 (with ring insert)	50x50 / Ø 45	50x50 / Ø 50		
cylinder-take-up-diameter =	D	40	45	50	60
size	A	20	20	20	20
	B	50	50	50	60
	C	35	35	35	50
	H	25	25	25	30
material	aluminum				