

SUPERMASTER

Chain actuator - Force in push action 400 N - Stroke 450-600-800 mm



- The longest stroke (800 mm) and the highest force (400 N) for a chain actuator: it solves the problems to operate very heavy vents and the necessity of wide opening without taking up space inside the room (800 mm only for bottom hinged windows).
- Double link chains.
- Red lamp placed on the actuator to signal the window closed position.
- Supplied with 2 m cable (450-600 mm), 3 m cable (800 mm).
- For windows without windowsill a fixing bracket (sliding within the dovetail slide) is available for an easy installation.
- Minimum window height: 900 mm for 450 mm stroke, 1200 mm for 600 mm stroke, 1600 mm for 800 mm stroke. In case of lower windows install the "pivoting brackets" part No. 40560T (see installation examples).
- In case of vents with four-bar hinges, please contact our Technical Dpt. for choosing the suitable fixing brackets.
- Available on request a coupling control box for two actuators on the same window.
- 24 Vcc version is suitable for installation on smoke and heat extraction systems in conformity to UNI EN 12101-2.
- (*) SUPERMASTER 24 Vdc approved by TÜV test (Nr. KH99.8.2).



STROKE
 VOLTAGE SUPPLY
 ELECTRIC CONNECTION
 OPERATION
 FORCE (push action)
 FORCE (pull action)
 SPEED
 CURRENT ABSORPTION (with max load)
 PARALLEL CONNECTION
 LIMIT STOP
 END STROKE POSITION SIGNAL
 SAFETY STOP
 PROTECTION CLASS

SUPERMASTER 230 V AC

450 - 600 - 800 mm
 230 Vac \pm 10%
 3 wires + earth
 by polarity inversion
 400 N (300 N for 800 mm stroke)
 400 N
 ~ 23 mm/s
 0,8 A
 YES
 Micro switches
 Thermic
 IP 20

SUPERMASTER 24 V DC *

450 - 600 - 800 mm
 24 Vdc \pm 10%
 3 wires
 by polarity inversion
 400 N (300 N for 800 mm stroke)
 400 N
 ~ 20 mm/s
 2 A
 YES
 Micro switches
 Opening/Closing
 Electronic
 IP 20

PART No.

STROKE
 SILVER ALUMINIUM
 DARK BROWN ANODIZED
 WHITE PAINTED RAL 9010

	450 mm	600 mm	800 mm	450 mm	600 mm	800mm
	40462T	40452P	40518U	40506L	40461R	40469H
	40465Z	40464X	40753T	40509T	40467D	40470S
	40466B	40454U	40774O	40507N	40468F	40471U

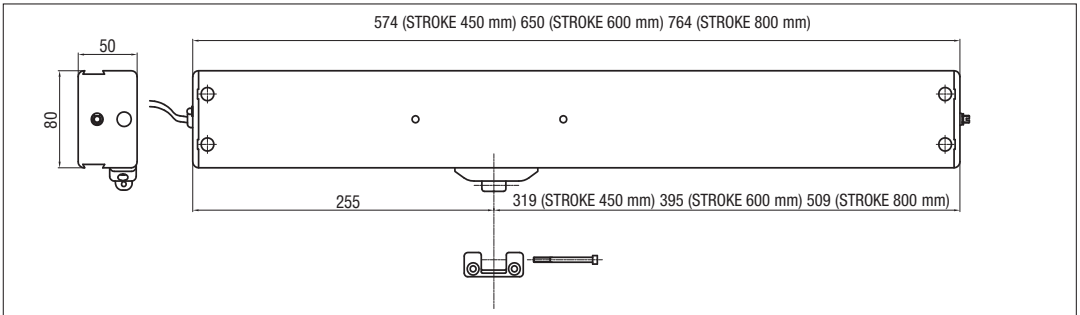

Actuators dimension

SPECIFICATION PROSPECTS

Electric chain actuator Ultraflex Control Systems named Supermaster with double link chain. Force 400 N. Strokes: 450-600-800 mm. Voltage supply 230 Vac or 24 Vdc. Limit stop by micro switches and thermal protection (230 Vac version) or electronic safety stop (24 Vdc version). Parallel connection. Casing in silver anodized or painted aluminium. The 230 Vac version and the 24 Vdc version are conform to 2004/108/CE directive, the 230 Vac version is also conform to 2006/95/CE directive.

Accessories

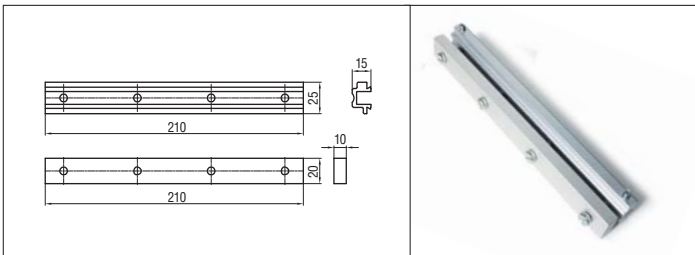

Sliding aluminium bracket with shim part No. 40460N

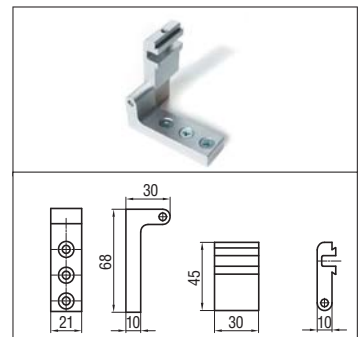

Pivoting brackets kit part No. 40560T

Installation examples

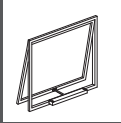

Top hinged windows

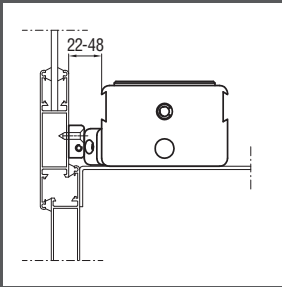

On windows with windowsill without brackets

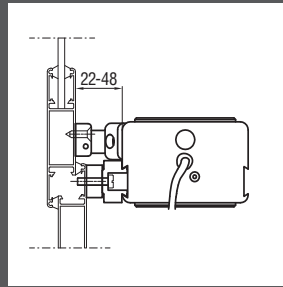

Without windowsill with bracket part No. 40460N

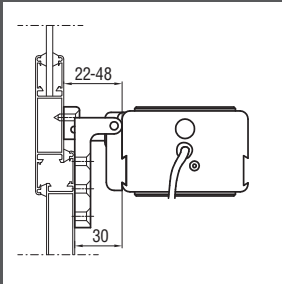

On the frame with pivoting brackets part No. 40560T

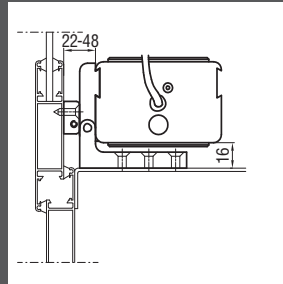

On windows with windowsill with pivoting brackets part No. 40560T

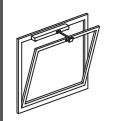

Bottom hinged windows

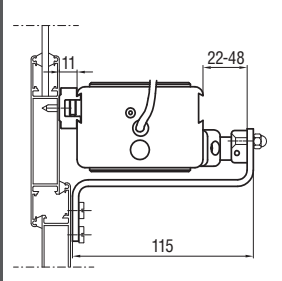

On the frame with bracket or bottom hinged window part No. 40472W

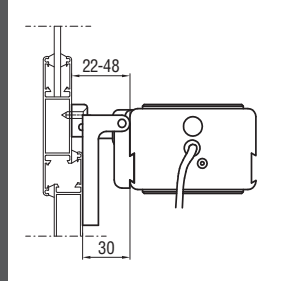

On the vent with the pivoting bracket part No. 40560T

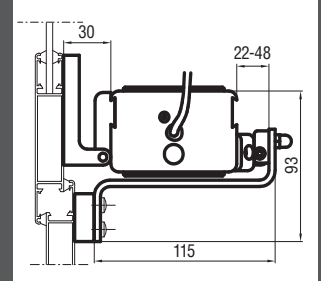

On the frame with the pivoting bracket part No. 40560T and bracket part No. 40472W

 The instructions for a safe installation are included in the section "SECURITY WARNINGS"

Accessories

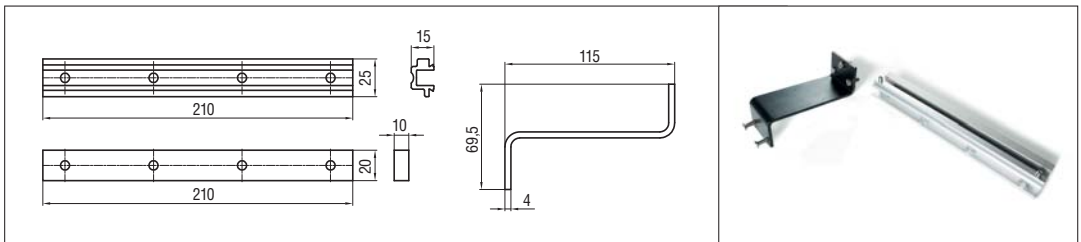

Sliding aluminium steel bracket with shim and bottom hinged painted steel bracket part No. 40472W