

**INSTALLATION AND MAINTENANCE INSTRUCTIONS  
FOR SMK400E SURFACE MOUNTING ADAPTOR KIT  
FOR USE WITH 100, 200, 400 OR 500 SERIES PLUG-IN DETECTORS**

**GENERAL DESCRIPTION**

The SMK400E Surface Mounting Adaptor Kit allows 100, 200, 400 or 500 series plug-in detectors to be surface mounted when the ceiling construction prevents the use of conventional recessed metal electrical junction boxes.

This kit consists of the following parts:

- 1 - Plastic Surface Mount Adaptor
- 2 - Screws (Ø4 x 12 mm)

**MOUNTING INSTRUCTIONS**

1. Read the installation instructions appropriate for the detector head to be used, and determine the number of wires used.
2. Drill or knockout the appropriate holes (see Figure 1).
3. Mount the adaptor on the ceiling using the mounting holes (see Figure 2) and appropriate screws or bolts (not included). The screws or bolts must be long enough to go through the adaptor (5/32" or 4 mm) and still fasten securely to the ceiling.
4. Locate a B401 or B501 base over the wires and using 2 screws supplied fix to base mounting pillars - do not overtighten screws.
5. Wire the detector mounting base per the installation instructions provided.
6. Plug the detector head into its mounting base and rotate clockwise.

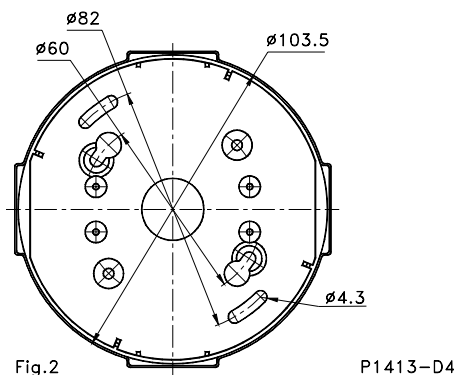
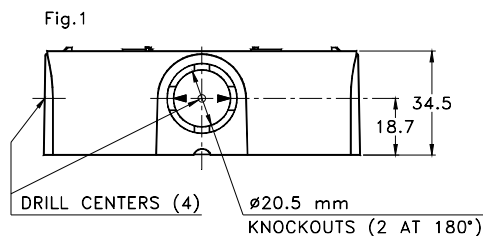

**INSTALLATION AND MAINTENANCE INSTRUCTIONS  
FOR SMK400E SURFACE MOUNTING ADAPTOR KIT  
FOR USE WITH 100, 200, 400 OR 500 SERIES PLUG-IN DETECTORS**

**GENERAL DESCRIPTION**

The SMK400E Surface Mounting Adaptor Kit allows 100, 200, 400 or 500 series plug-in detectors to be surface mounted when the ceiling construction prevents the use of conventional recessed metal electrical junction boxes.

This kit consists of the following parts:

- 1 - Plastic Surface Mount Adaptor
- 2 - Screws (Ø4 x 12 mm)

**MOUNTING INSTRUCTIONS**

1. Read the installation instructions appropriate for the detector head to be used, and determine the number of wires used.
2. Drill or knockout the appropriate holes (see Figure 1).
3. Mount the adaptor on the ceiling using the mounting holes (see Figure 2) and appropriate screws or bolts (not included). The screws or bolts must be long enough to go through the adaptor (5/32" or 4 mm) and still fasten securely to the ceiling.
4. Locate a B401 or B501 base over the wires and using 2 screws supplied fix to base mounting pillars - do not overtighten screws.
5. Wire the detector mounting base per the installation instructions provided.
6. Plug the detector head into its mounting base and rotate clockwise.

