

Smoke and heat vent control unit

5A – 1 – 1

5,0A max. rated motor current at 24V DC

1 Ventilation group

1 Smoke and heat vent group



Technical Documentation

BSC Technology GmbH
Dr.-Köhl-Straße 6
D-95119 Naila

Telephone (main number)
+49 9282 48731-0

windowdrives.com

Fax (main number)
+49 9282/48731-29

mail: info@bsc-technology.de



WINDOWDRIVES
BSC TECHNOLOGY

1 Contents

	Page
1 Contents	2
1.1 List of figures.....	2
2 Equipment diagram.....	3
3 Installation	4
3.1 General	4
3.2 Regulations and installation instructions.....	4
3.3 Accident prevention regulations.....	4
3.4 Layout of the control unit.....	4
3.5 Connecting the Smoke and Heat Vent Control Unit 5A-1-1	5
3.6 Overview circuit diagram.....	6
3.7 Connecting the motor openers	7
3.7.1 Determining the cable cross-sections	8
3.7.2 Cable types.....	9
3.8 Connecting the smoke and heat vent switches	10
3.9 Connecting the ventilation pushbuttons and wind/rain detector system.....	12
3.10 Relaying of trigger and fault states.....	13
3.11 Connecting the batteries	13
4 Functional description.....	14
4.1 Smoke and heat vent (triggered) operation	14
4.2 Ventilation mode	14
4.3 Comfort ventilation module	15
4.3.1 Stroke limitation	15
4.3.2 Automatic Close.....	15
4.4 Open display	15
4.5 Site of installation.....	15
5 Commissioning	16
6 Operator action.....	18
6.1 Display and operator control elements on the board.....	18
6.2 Audible signals.....	20
6.3 Fuses on the board	21
6.4 State at time of delivery	21
7 Programming (SETUP).....	22
8 Locating faults / troubleshooting	23
9 Maintenance	24
10 Technical data	25
11 Annex with circuit diagrams	

1.1 List of figures

Fig.1: View of smoke and heat vent control unit 5A-1-1	3
Fig. 2: Terminal connection plan	5
Fig. 3: Overview circuit diagram.....	6
Fig.4: Connection of motor opener 24V DC.....	7
Fig.5: Connecting the smoke and heat vent switches.....	10
Fig. 6: Smoke and heat vent switches 6 and 7	11
Fig. 7: Connection of wind/rain detectors and ventilation pushbuttons.....	12
Fig. 8: Falt and trigger relays.....	13
Fig. 9: Connection of batteries	13
Fig. 10: Displays and controls	18
Fig.11: Displays and control	22

2 Equipment diagram

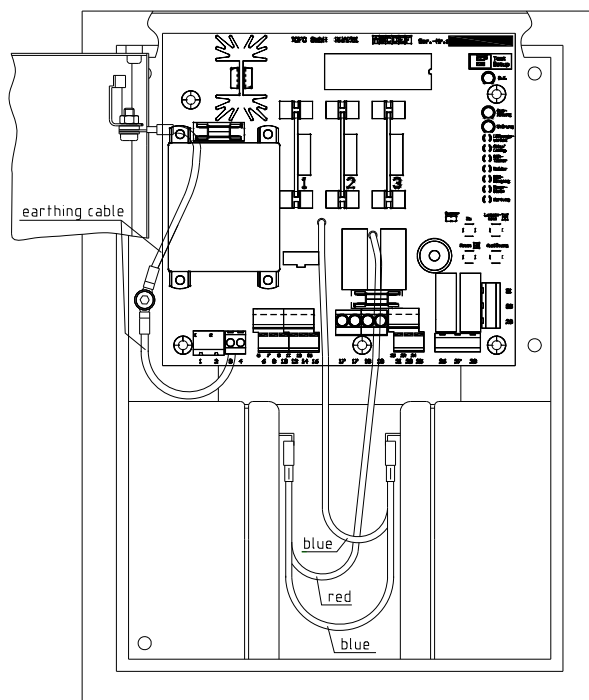

battery connection

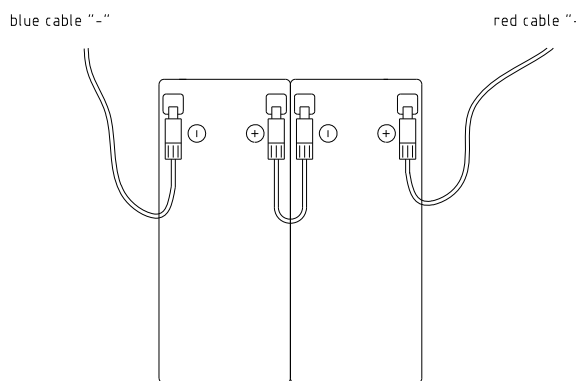

Batteries: 2 x 12 V ,7,0 Ah or 7,2 Ah

Fig.1: View of smoke and heat vent control unit 5A-1-1

3 Installation

3.1 General

Installation, commissioning, repair and maintenance of the Smoke and Heat Vent Control Unit 5A-1-1 should only be carried out by trained specialists

3.2 Regulations and installation instructions

The following regulations and instructions must be observed during installation, cabling and commissioning work:

- national building regulations
- DIN 18232 – Structural fire safety in industrial buildings
- VDS Directive 2098
- regulations of the competent fire safety authorities
- guideline ZH 1/494 for power-operated windows, doors and gates
- VDE 0100, VDE 0108
- the rules of the competent power supply company
- the control unit should be installed in a location that allows unobstructed access to the control unit for subsequent maintenance and repair work
- the housing must be fastened to the wall
- for the 230V AC supply shall be provided to external isolation facility

Important note:

The batteries must be charged for at least 12 hours before commissioning can begin. When connecting the batteries, it is of the utmost importance to ensure the correct polarity.

3.3 Accident prevention regulations

The general accident prevention regulations, the accident prevention regulations for power-operated windows, doors and gates, and the VDE installation regulations must be obeyed at all times.

Important warning

The system must be isolated from voltage before any components are removed.

- **first disconnect the 230 V mains voltage**
- **then disconnect the batteries**
- **To protect the electronic components, before carrying out work on the board the installation technician must earth him or herself → by touching the earthing connector**
- **when switching on the system again, the voltages are reconnected in reverse sequence**

3.4 Layout of the control unit

The Smoke and Heat Vent Control Unit 5A-1-1 has 1 motor line, 1 manual detector line, 1 automatic detector line and one input for the BMZ (**B**rand- **M**elde- **Z**entrale - fire alarm unit) which make it possible to connect the following components:

- **Motors:** Six model JM – DC - ... 24 V / 0.8 A motors with associated external load disconnecter can be connected. If another motor is connected, the number of motors in each motor line is limited by the current consumption. The maximum breaking capacity of the motor line is 5,0 A.
- **Detectors:** Up to 10 smoke and heat vent switches can be connected to the manual detector line. Up to 50 automatic detectors [optical smoke detectors, maximum heat detectors or differential heat detectors] can likewise be connected in the automatic detector line on 1- or 2-detector configuration.

3.5 Connecting the Smoke and Heat Vent Control Unit 5A-1-1

The Smoke and Heat Vent Control Unit 5A-1-1 is equipped with terminal blocks on the board where all the necessary connections can be made, both incoming and outgoing. The cables are routed from the rear through the aperture for that purpose at the bottom of the box. The cables can be routed from above or below behind the bottom of the box.

The following illustration shows the positions of the individual terminals on the board:

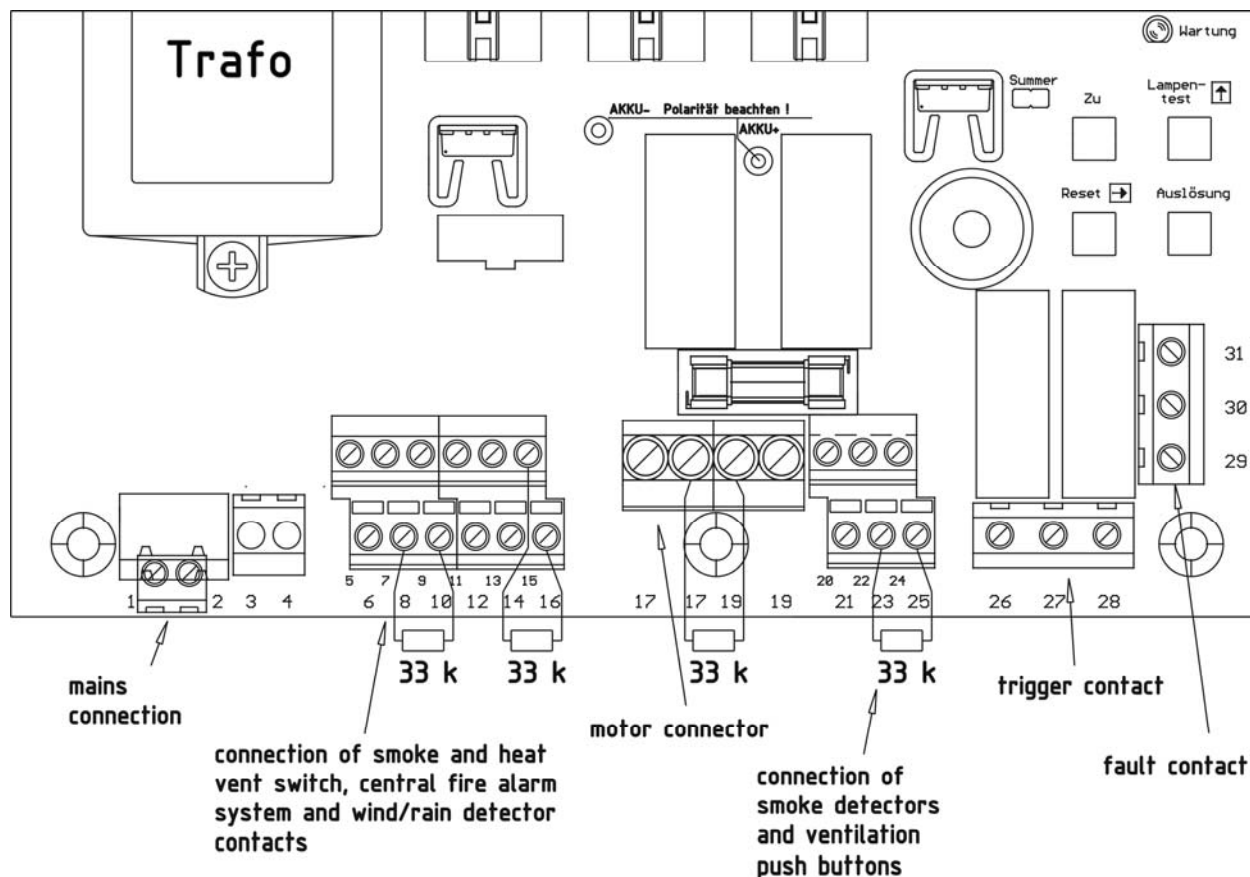

Fig. 2: Terminal connection plan

All of the terminals are arranged on the lower part of the board, and are easily accessible using a suitable screwdriver. Located on the right side is the clearly structured operator control and display panel of the Smoke and Heat Vent Control Unit. The fuse SI2 for the motor line is located underneath the all-or-nothing relay. Fuse SI1 is located above the transformer.

3.6 Overview circuit diagram

The following illustration depicts the entire smoke and heat vent system with the associated external components. Although depending on the specific application not all external components may be required, they will be shown here in the interests of completeness.

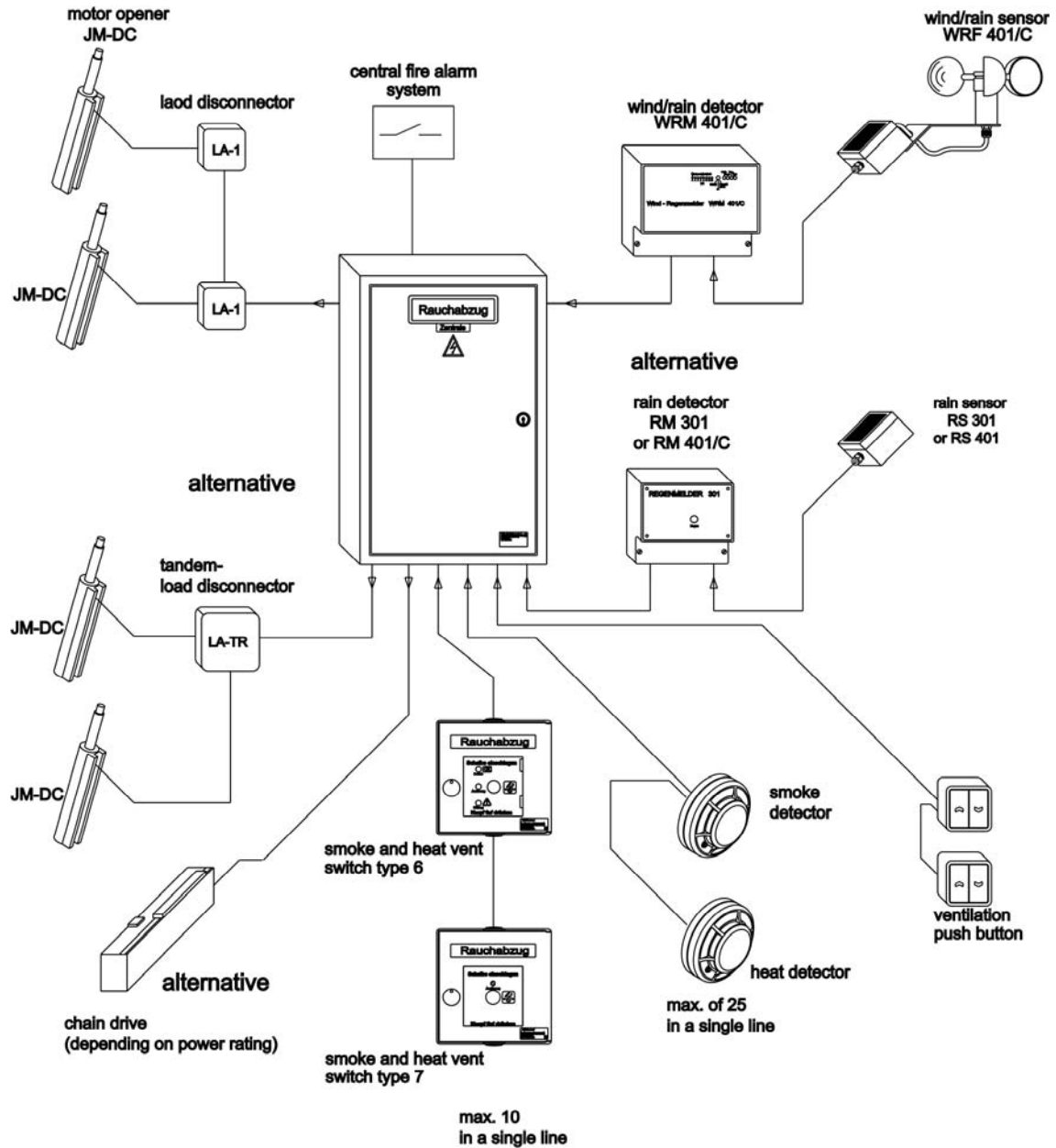

Fig. 3: Overview circuit diagram

The following sections will describe how and where the individual external components are connected to the Smoke and Heat Vent Control Unit.

!!!! Connection of all devices, such as detectors, motors etc. is shown in detail in the circuit diagrams in the Appendix.

3.7 Connecting the motor openers

The Smoke and Heat Vent Control Unit 5A-1-1 has 1 motor line with a maximum breaking capacity of 5,0A.

These motors must always remain connected to a load disconnecter (LA-1 → stand-alone operation, LA-TR → tandem operation, LA-GL2 or LA-GL/A parallel operation).

The following illustration shows an example of motor connections in stand-alone and tandem operation on the motor line:

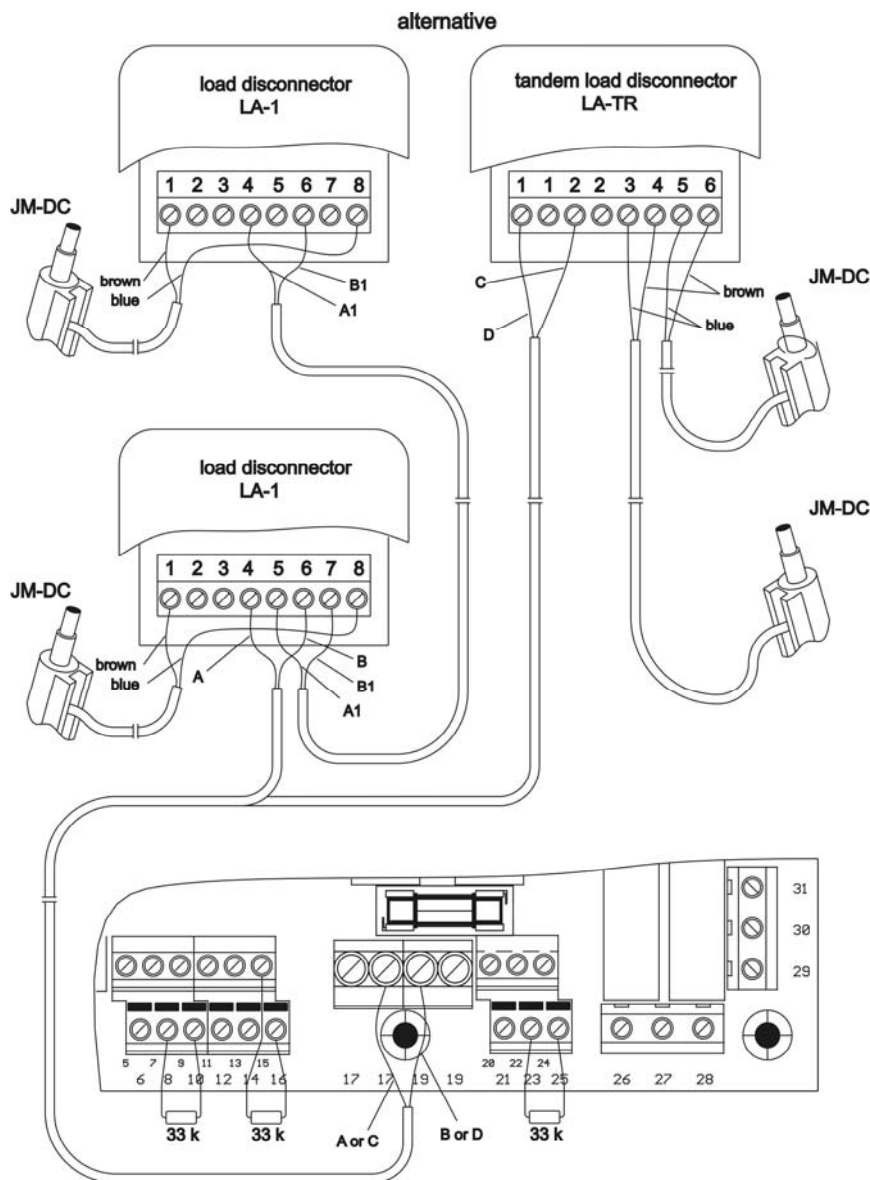

Fig.4: Connection of motor opener 24V DC

When connecting chain drives and third-party drives, the separate circuit diagrams in the Appendix must be observed.

If no model JM – DC - ... motor opener with its associated load disconnecter is connected to a line, **then the line must be terminated by means of a 33 KΩ resistor**. This resistor is used in monitoring the motor line for line breaks. A 33 KΩ terminal resistor is likewise required when connecting third-party drives with switch-off by means of limit switches in the end positions. This is installed on the motor via the + and – terminals.

3.7.1 Determining the cable cross-sections

When 24 V DC motor openers are used, the length of the motor supply cables is limited due to voltage drop. In such cases, the maximum permissible cable length is determined by the number of motors operated on a motor line and by the cable cross-section.

The following table shows the maximum permissible cable length depending on the **rated current of the connected motor openers** and the cable cross-section :

Current consumption(I) each motor line in [A]	Number of wires required (without earthing conductor)	Maximum permissible simple cable length to the last motor [m]
up to 0.5A	2 x 1.5mm ²	168m
up to 0.5A	2 x 2.5mm ²	280m
up to 0.5A	2 x 4mm ²	449m
up to 0.5A	2 x 6mm ²	674m
0.5A to 1A	2 x 1.5mm ²	84m
0.5A to 1A	2 x 2.5mm ²	140m
0.5A to 1A	2 x 4mm ²	224m
0.5A to 1A	2 x 6mm ²	337m
1A to 1.5A	2 x 1.5mm ²	56m
1A to 1.5A	2 x 2.5mm ²	93m
1A to 1.5A	2 x 4mm ²	149m
1A to 1.5A	2 x 6mm ²	224m
1.5A to 2A	2 x 1.5mm ²	42m
1.5A to 2A	2 x 2.5mm ²	70m
1.5A to 2A	2 x 4mm ²	112m
1.5A to 2A	2 x 6mm ²	168m
2A to 2.5A	2 x 1.5mm ²	33m
2A to 2.5A	2 x 2.5mm ²	56m
2A to 2.5A	2 x 4mm ²	89m
2A to 2.5A	2 x 6mm ²	134m
2.5A to 3A	2 x 1.5mm ²	28m
2.5A to 3A	2 x 2.5mm ²	46m
2.5A to 3A	2 x 4mm ²	74m
2.5A to 3A	2 x 6mm ²	112m
3A to 3.5A	2 x 1.5mm ²	24m
3A to 3.5A	2 x 2.5mm ²	40m
3A to 3.5A	2 x 4mm ²	64m
3A to 3.5A	2 x 6mm ²	96m
3.5A to 4A	2 x 1.5mm ²	21m
3.5A to 4A	2 x 2.5mm ²	35m
3.5A to 4A	2 x 4mm ²	56m
3.5A to 4A	2 x 6mm ²	84m
4A to 4.5A	2 x 1.5mm ²	18m
4A to 4.5A	2 x 2.5mm ²	31m
4A to 4.5A	2 x 4mm ²	50m
4A to 4.5A	2 x 6mm ²	75m

Current consumption(I) each motor line in [A]	Number of wires required (without earthing conductor)	Maximum permissible simple cable length to the last motor [m]
4.5A to 5A	2 x 1.5mm ²	16m
4.5A to 5A	2 x 2.5mm ²	28m
4.5A to 5A	2 x 4mm ²	44m
4.5A to 5A	2 x 6mm ²	67m
4.5A to 5A	2 x 10mm ²	112m

The following table shows the maximum permissible cable length depending on the number of **24V DC pulsed-current remote triggers**) and the cable cross-section:

Number of remote triggers	Number of wires required (without earthing conductor)	Maximum permissible simple cable length to the last motor [m]
1	2 x 1.5mm ²	420
1	2 x 2.5mm ²	700
2	2 x 1.5mm ²	210
2	2 x 2.5mm ²	350
3	2 x 1.5mm ²	140
3	2 x 2.5mm ²	233
4	2 x 1.5mm ²	105
4	2 x 2.5mm ²	175
5	2 x 1.5mm ²	84
5	2 x 2.5mm ²	140
6	2 x 1.5mm ²	70
6	2 x 2.5mm ²	116
7	2 x 1.5mm ²	60
7	2 x 2.5mm ²	100
8	2 x 1.5mm ²	52
8	2 x 2.5mm ²	87

3.7.2 Cable types

All cable types must always be approved by the responsible building authorities, fire safety authorities, or the local fire brigade.

3.8 Connecting the smoke and heat vent switches

The following illustration shows the connection of the smoke and heat vent switches and automatic detectors to the Smoke and Heat Vent Control Unit 5A-1-1.

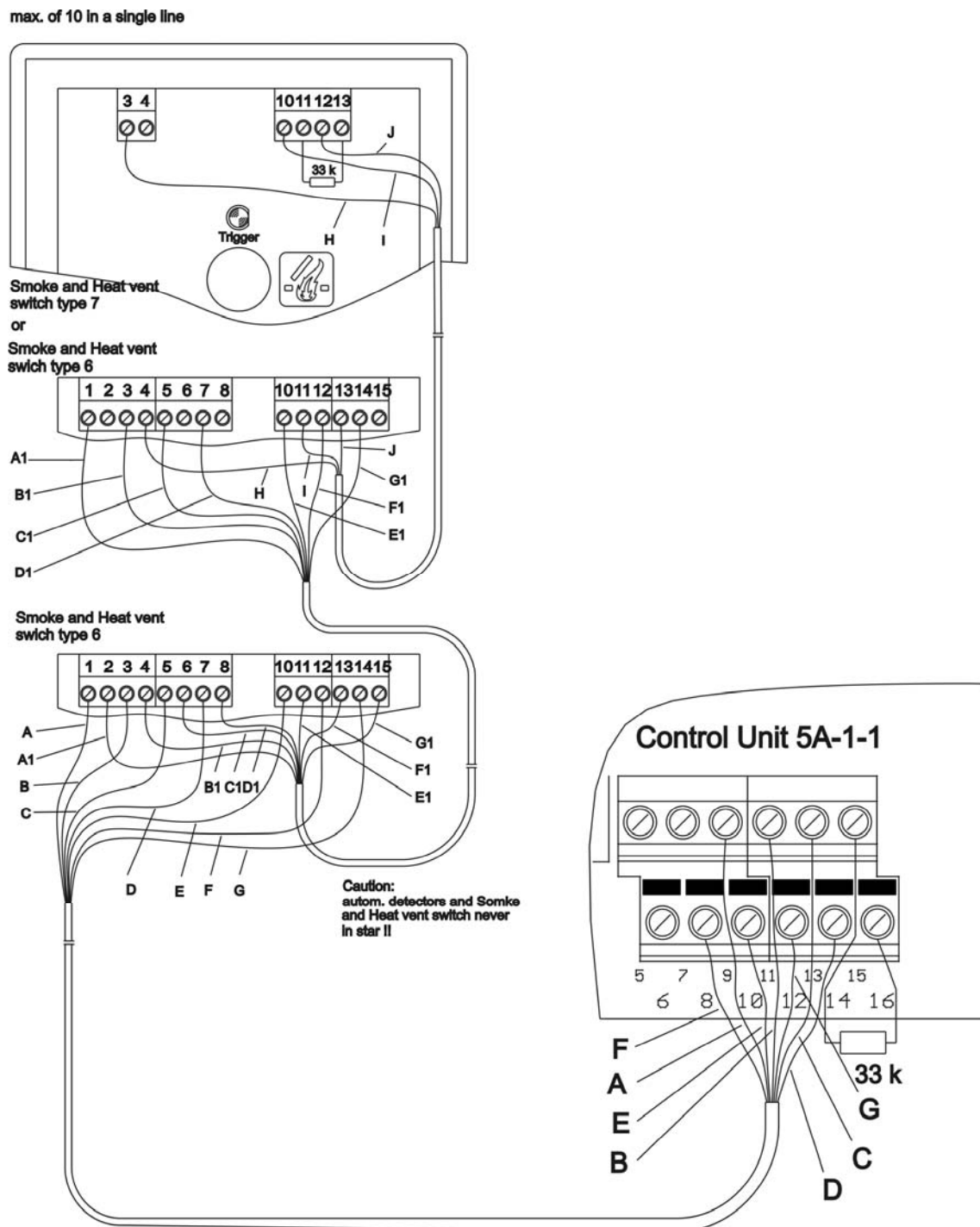

Fig.5: Connecting the smoke and heat vent switches

Depending on the switch type, the manual detectors (unit switch 6 and / or unit switch 7) use 7- or 3-strand cables. **As in the motor line, a 33 KΩ resistor must be connected in the last detector for the purposes of cable monitoring.**

The smoke and heat vent switches are divided into two types according to their various displays and functions:

Smoke and heat vent switch 6: (main control position acc. to EN 12101-9 and VdS 2592)

- "Trigger smoke and heat vent" pushbutton
- "Reset" pushbutton
- „Close“ pushbutton
- „Trigger“ LED
- „Fault“ LED
- „Mode“ LED

Smoke and heat vent switch 7: (secondary control position acc. to EN 12101-9 and VdS 2592)

- "Trigger smoke and heat vent" pushbutton
- "Trigger" LED

The following illustrations show the two smoke and heat vent switches:



Smoke and heat vent switch 6



Smoke and heat vent switch 7

Fig. 6: Smoke and heat vent switches 6 and 7

When connecting more than one smoke and heat vent switch, it must be ensured that the cables are routed from one smoke and heat vent switch to the next. Only in this way will it be possible to monitor the line properly with the aid of the 33 KΩ resistor.

3.9 Connecting the ventilation pushbuttons and wind/rain detector system

The following illustration shows the connection of the ventilation pushbuttons (double rocker switch without mutual interlock) and the connection of wind/rain detectors to the Smoke and Heat Vent Control Unit.

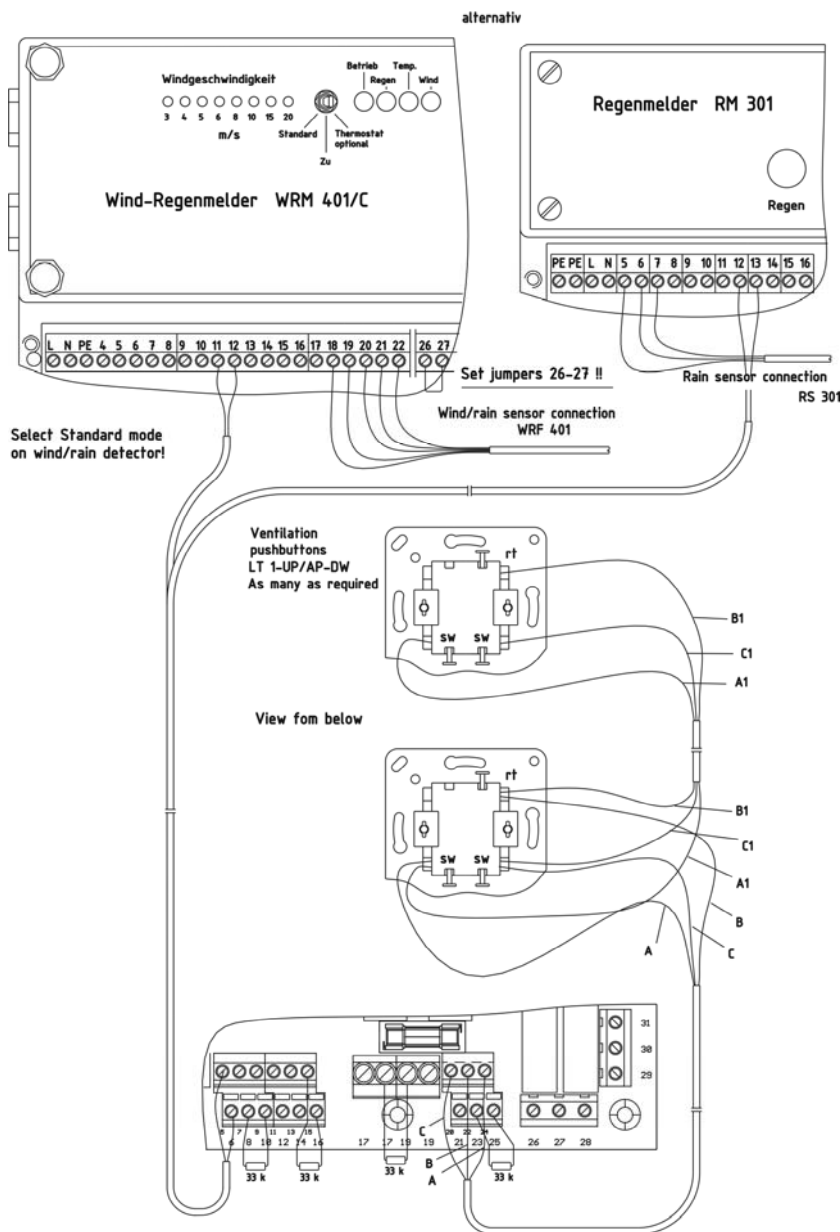

Fig. 7: Connection of wind/rain detectors and ventilation pushbuttons

As many ventilation pushbuttons as desired can be connected to each motor line. The ventilation pushbuttons make use of three-strand cables.

A wind/rain detector system can be connected to the Smoke and Heat Vent Control Unit 5A-1-1 for priority closing of the opening devices in ventilation mode. The illustration above shows the connection of the (W)RM 401/C wind/rain detector system and connection of the RM 301 rain detector. It is also possible to connect a third-party product, provided that it is equipped with a floating make contact.

To ensure proper functioning of the wind/rain detector, the technical documentation of the wind/rain detector must also be observed.

3.10 Relaying of trigger and fault states

Two relays, each with a floating changeover contact, are provided to pass on the trigger and fault state (see illustration).

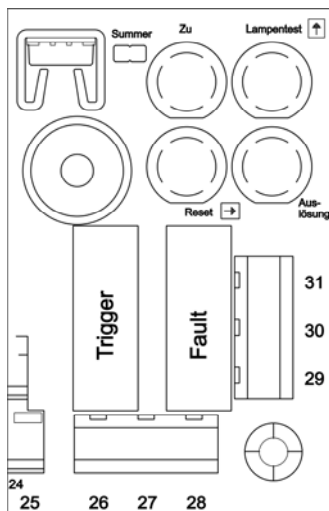

The fault relay (terminals 29, 30, 31) is used for the floating relay of faults. The trigger relay (terminals 26, 27, 28) is used for the relay of trigger signals.

Both relays (floating changeover contacts) can switch over at 60 V 3 A.

In the normal state, the fault relay is picked up; it drops out in the event of a fault.

<u>Contact closed:</u>	Terminals 29 + 30: Fault
	Terminals 30 + 31: No fault
	Terminals 27 + 28: No trigger
	Terminals 26 + 27: Trigger

Fig. 8: Fault and trigger relays

3.11 Connecting the batteries

When connecting the batteries, it is of the utmost importance to ensure the correct polarity. **A wrong connection will always result in immediate destruction of the board.** The red wire always indicates the positive terminal, and the blue wire always indicates the negative terminal of the battery. The leads for the batteries are soldered securely to the board. The lugs of the batteries are coded in the same colours.

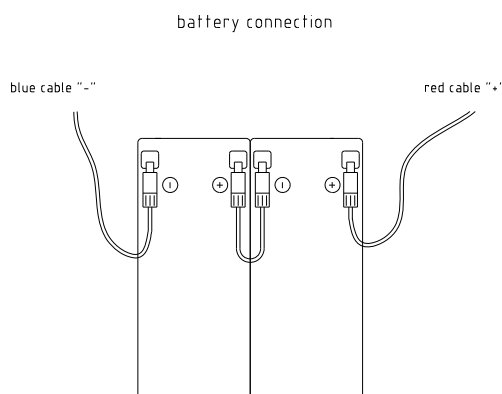

Fig. 9: Connection of batteries

The emergency power supply comprises two 12V / 7,0 or 7,2 Ah, batteries, which are connected in series to provide a combined 24 V DC. This is done by connecting the + terminal of one battery to the - terminal of the other battery. The two remaining terminals are then connected with the leads on the board. **(Red → Positive / Blue → Negative)**

4 Functional description

The Smoke and Heat Vent Control Unit 5A-1-1 is a smoke and heat vent control unit with an emergency power supply for 72 hours in the event of a power outage. It is used to open and close electric motor-driven smoke vents in the event of a fire, and also for everyday ventilation.

The functional description will be kept quite general at this point. The functions of the individual operator control and display elements will be described in more detail in the next section.

A distinction is made between two basic operating modes:

4.1 Smoke and heat vent (triggered) operation

In the event of a fire (triggered by smoke and heat vent pushbutton, smoke detector or heat detector or the fire alarm system), the connected opening elements open. Smoke and heat vent operation always has priority over ventilation mode; the batteries help to ensure that after 72 hours of power outage the system can still be opened twice and closed once (smoke and heat vent operation). It can be triggered manually by pressing the "Trigger" pushbutton on the external smoke and heat vent switches, or automatically when one of the automatic detectors or the fire alarm system is triggered. Triggering is also possible when a power outage has lasted longer than 72 hours.

When necessary, or when the fire brigade so desires, the connected opening elements can be given a Reset command and then closed again. To do this, first the smoke and heat vent alarm is acknowledged by pressing the "Reset pushbutton" on the smoke and heat vent switch or on the board. Then the opening elements can be closed again by pressing the "Close pushbutton" on smoke and heat vent switch 6, the individual ventilation pushbuttons, or the "Close pushbutton" on the board.

Smoke and heat vent operation has priority over ventilation mode, i.e. operation in ventilation mode is not possible during a smoke and heat vent operation alarm.

4.2 Ventilation mode

Three different ventilation modes (Continuous / Open only / Open and Close) can be set on the board. The settings are made in Set-up mode (see [Programming](#)).

The connected opening elements can be opened and closed by means of the individual ventilation pushbuttons

In „Continuous“ mode, pressing the Open pushbutton at the ventilation pushbutton once moves the motor to the Open end position, and pressing the Close pushbutton once moves it to the Closed end position. Both pushbuttons can be pressed simultaneously to hold the motor in an intermediate position.

In „Push“ position, the motor can be moved in the Open direction only so long as the Open pushbutton on the ventilation pushbutton is held pressed. If the Close pushbutton on the ventilation pushbutton is pressed, the motor moves to its Closed end position („Push Open only“ mode). In „Push Open and Close“ mode, the drive also moves in Close direction.

If a wind/rain detector is connected, its function has priority over normal ventilation mode, i.e. in the event of a rain/wind alarm the connected opening elements are closed automatically, and can only be opened again manually after the rain/wind alarm has dropped out.

Operation in ventilation mode is not possible during a power outage.

“No ventilation” is also issued when a battery undervoltage is detected (*the battery cannot allow additional ventilation because otherwise operation for 72 hours under emergency power would no longer be possible*). This is signalled by means of a red LED on the board+.

4.3 Comfort ventilation module

If the optional comfort ventilation module is installed, the following additional ventilation functions can be used.

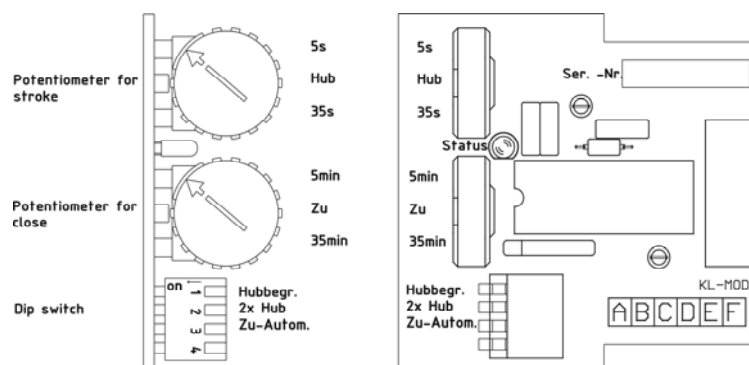

4.3.1 Stroke limitation

To enable the stroke limitation function, move the „Stroke limit.“ dip switch to „ON“ position (left). The „Continuous“ ventilation mode should be set.

An opening between 5s and 35s can be set at the „Stroke“ potentiometer. If the ventilation pushbutton moves to Open, the motor is actuated only the time set in the previous step.

Dip switch „2x stroke“ actuates the set opening time twice. The maximum opening time is double the time set. However, the ventilation pushbutton should be pressed at least twice.

The connected drive can perform an Open movement only for the time set even if the motor has meanwhile (while the set time is running) been instructed to Close.

Example:

- Time set = 20 seconds
- The pushbutton moves the motor Open
- After 10 seconds it moves Close for 5 seconds
- After that, it moves Open again with the ventilation pushbutton
- → the motor will open only for another 15 seconds !!!!!

4.3.2 Automatic Close

To enable the automatic Close, the „Autom. Close“ dip switch should be set to „ON“ position (left). An automatic time between 5s and 35s can be set at the „Close“ potentiometer. The time starts after the last move instruction (Open or Close). The time is reset automatically after at least 8 minutes of Close and the Open display has extinguished.

4.4 Open display

The smoke and heat vent control unit has an output (24V DC, 50 mA) for the Open display. If the connected drive moves Open, this output is switched. If after a Close instruction the connected drive is at least 8 minutes in Close state, the display extinguishes (the output is reset).

The Open display works without feedback from the drive by assuming that the drive is closed if it moves close for at last 8 minutes. The Open display is switched off in this case.

Each time the Open drive is actuated, the Open display is switched on again.

4.5 Site of installation

The modules must only be installed or removed when the smoke and heat vent control unit is isolated electrically (battery and mains supply disconnected). The slot for the comfort ventilation module should be in the first slot.

5 Commissioning

Commissioning is possible once all necessary external devices have been connected, the wiring has been double-checked, and the batteries have been charged. First the power supply must be ensured. Only when the batteries have been connected can the mains voltage (230 V AC) be switched on; the green "Mode" LED's on the board and on smoke and heat vent switch 6 light up.

When connecting the batteries, it is of the utmost importance to ensure the correct polarity. Connecting the batteries incorrectly will result in immediate destruction of the board.

The Smoke and Heat Vent Control Unit is now ready for operation, and the individual functions can be tested in turn.

The following functions must be tested during commissioning:

Ventilation function:

Push ventilation pushbutton in the Open direction	- Motors open
Push ventilation pushbuttons in the Open and Closed directions simultaneously	- Motors stop
Push ventilation pushbutton in the Closed direction	- Motors close
Triggering of a rain alarm on the rain detector (push the test pushbutton if present)	- all motors close
Motors should be in the open position!	

Smoke and heat vent function (triggered by Smoke and heat vent function pushbutton, autom. detector or fire alarm system contact):

Move the mode selector switch to "Test" and trigger the smoke and heat vent by pressing the red "Alarm" pushbutton on the board	<ul style="list-style-type: none"> - The green "Mode" LED on the board blinks (Test mode) - all motors open - The red LED's on the board and on the smoke and heat vent switches blink - The signal buzzer sounds with an alternating frequency
Make the Smoke and Heat Vent Control Unit ready for operation again by pressing the "Reset" pushbutton on the board. Then close the motors by means of the "Close pushbutton" on the board. (Mode selector switch remains in the "Test" position)	<ul style="list-style-type: none"> - all motors close - red LED trigger extinguishes - the buzzer goes silent - The green "Mode" LED on the board blinks (Test mode)
Trigger the smoke and heat vent by pressing the "Alarm" pushbutton on the smoke and heat vent switch (mode selector switch remains in the "Test" position)	<ul style="list-style-type: none"> - all motors open - The red LED trigger on the board and on the smoke and heat vent switches blink - The signal buzzer sounds with an alternating frequency - The green "Mode" LED on the board blinks (Test mode)
Make the Smoke and Heat Vent Control Unit ready for operation again by pressing the "Reset" pushbutton on the smoke and heat vent switch. Then close the motors by means of the "Close" pushbutton on the smoke and heat vent switch (mode selector switch remains in the "Test" position)	<ul style="list-style-type: none"> - all motors close - red LED trigger extinguishes - The signal buzzer goes silent - The green "Mode" LED on the board blinks (Test mode)
Use test unit for signal series type ECO 1000RTU to trigger an automatic ECO type detector (mode selector switch remains in the "Test" position)	<ul style="list-style-type: none"> - all motors open - The red "Alarm" LED's on the board and on the smoke and heat vent switches blink - The signal buzzer sounds with an alternating frequency - The green "Mode" LED on the board blinks (Test mode)
Make the Smoke and Heat Vent Control Unit ready for operation again by pressing the "Reset" pushbutton on the board. Then close the motors by means of the "Close pushbutton" on the board. (Now move mode selector	<ul style="list-style-type: none"> - all motors close - red LED trigger extinguishes - the buzzer goes silent - The green "Mode" LED on the board is

switch to the "Normal" position)	lit continuously (Normal operation)
----------------------------------	-------------------------------------

6 Operator action

6.1 Display and operator control elements on the board

The Smoke and Heat Vent Control Unit 5A-1-1 has a number of operator control and display elements on the board, thus providing a clear, detailed indication of the individual operating states and faults. The operator control elements can be used to make various settings and activate various functions on the Smoke and Heat Vent Control Unit. The following illustration shows the operator control elements on the board of the Smoke and Heat Vent Control Unit 5A-1-1:

With the exception of the ventilation function, the Smoke and Heat Vent Control Unit can be operated from the board alone

The following operator control elements are available:

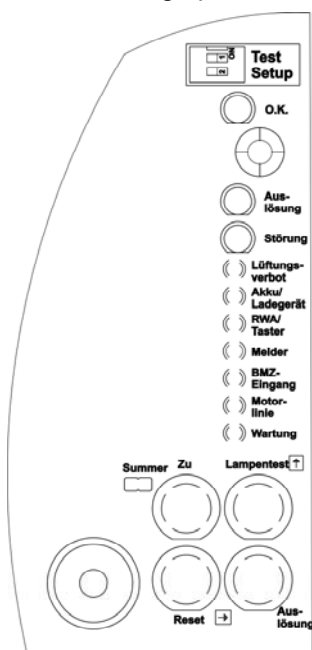

- Pushbutton „Trigger“
- Pushbutton „Reset“ →
- Pushbutton „Close“
- Pushbutton „Lamp test“ ↑
- Jumper „Buzzer“
- Slide switch „Test“
- Slide switch „Setup“



The following additional display elements are available:

- green LED Mode („O.K.“)
- red LED „Trigger“
- yellow LED „Fault“
- LED „No ventilation“
- LED „Battery / charger“
- LED „Smoke and heat vent switch“
- LED autom. detectors („Detector“)
- LED „Fire alarm center input“
- LED „Motor line“
- LED „Maintenance“

Fig. 10: Displays and controls

The following table provides an overview of the various functions and settings of the individual operator control elements on the board of the Smoke and Heat Vent Control Unit

Operator action	Function / effect
Pressing the „Trigger“ pushbutton	<ul style="list-style-type: none"> - all motors open - The red trigger LED on the board and on the smoke and heat vent switches blink - The signal buzzer sounds with an alternating frequency - Automatic alarm forwarding is active
Pressing the „Reset“ pushbutton	<ul style="list-style-type: none"> - Triggering of smoke and heat vent is reset - The signal buzzer goes silent - Automatic alarm forwarding is inactive - The red trigger LEDs on the board and on the smoke and heat vent switches are extinguished

Operation	Function / effect
Pressing the "Close" pushbutton	- All motors close (only if smoke and heat vent triggering is not present) → ventilation closed
Pressing the "Lamp test" pushbutton	- All LED's on the board and on the connected smoke and heat vent switches are lit; they are extinguished when the Reset pushbutton is pressed - The signal buzzer sounds as long as the "Lamp test" pushbutton is pressed - The lamp test automatically ends after 10 minutes
"Signal buzzer" jumper	- If the jumper is on, the internal signal buzzer is switched on when triggering or a fault occurs - If the jumper is off, the internal signal buzzer is not activated
"Mode" slide switch in "ON" position	- The Smoke and Heat Vent Control Unit is in Test mode - The green "Mode" LED on the board blinks - - Automatic alarm forwarding is inactive - The diagnostic LED's on the board can be activated in the event of a power outage
"Mode" slide switch in "OFF" position	- Normal state of the control unit - The fire brigade relay is switched when triggering occurs
"Setup" slide switch in OFF position	- Normal state of the control unit
"Setup" slide switch in ON position [Press Reset  and Lamp test  pushbuttons at the same time]	- Setup mode active (see Programming) - all LEDs blink at high frequency

The following table provides an overview of the various display states of the individual display elements on the board of the Smoke and Heat Vent Control Unit 5A-1-1:

Indicator	State
Mode LED („O.K.“)	- Is lit continuously so long as no fault is detected - blinks in Test mode - Is extinguished when a fault is active or maintenance is needed
"Trigger" LED	- blinks when smoke and heat vent is triggered
"Fault" LED	- blinks when a fault is detected - flashes during a power outage - blinks when maintenance is needed (see Maintenance LED)
"No ventilation!" LED	- Lit continuously when wind/rain alarm is active - blinks when the battery capacity drops below a certain limit (72 hours emergency power supply must be ensured)

Indicator	State
“Battery / charger” LED	<ul style="list-style-type: none">- blinks when battery not detected- flashes when there is exhaustive discharge of battery, is extinguished again when battery has been charged
“Smoke and heat vent switch” LED	<ul style="list-style-type: none">- lit constantly when triggering by an external control unit pushbutton occurs- blinks when there is a line interruption- flashes when there is a short circuit in the line
“Detector” LED	<ul style="list-style-type: none">- lit constantly when triggering is by an external automatic detector occurs- blinks when there is a line interruption- flashes when there is a short circuit in the line
“Central fire alarm system input” LED	<ul style="list-style-type: none">- lit constantly when triggering by an external Fire Alarm System occurs.- blinks when there is a line interruption- flashes when there is a short circuit in the line
“Motor” LED	<ul style="list-style-type: none">- Fault in the motor line- blinks when there is a line interruption / motor fuse SI2 defective (short circuit)
„Maintenance“ LED	<ul style="list-style-type: none">- blinks if maintenance is needed

6.2 Audible signals

When in operation, the control unit buzzer provides audible signals indicating fault states and action completed:

Caution !

The signals can be heard when the „Buzzer“ jumper is active.

Constant signal:

Fault state (The LED's indicate the cause)

or

Lamp test pushbutton is pressed (all LEDs light).

Constant signal with alternating pitch:

Control unit trigger state. The red „Trigger“ LED blinks.

1x long beep (confirm signal)

after exiting SETUP mode: Confirms that all settings have been adopted

6.3 Fuses on the board

To protect the electronic components, the board of the Smoke and Heat Vent Control Unit 2A-4-1 contains two fuses (glass tube fuses 5 x 20mm). The following table shows the functions and ratings of the individual fuses:

Designation:	Function:	Rating:
SI1	24 V AC secondary fuse downstream of transformer	0.4 A slow-blow
SI2	Motor line 1 fusing	5.0 A slow-blow

6.4 State at time of delivery



Because of the many options described here for setting the parameters of the Smoke and Heat Vent Control Unit 5A-1-1, the state of the control unit at the time of delivery will now be summarised in tabular form:

„Test“ slide switch	„Test“ slide switch is at position „OFF“ → automatic trigger forwarding in smoke and heat vent case
„Setup“ slide switch	Setup slide switch is at position „OFF“
„Buzzer“ jumper	Jumper is active → Buzzer is active
The following functions and settings, resp. are set in programming mode:	
Ventilation mode	set to constant mode
Serial resistance 0R / 18k function	set to 18k Ohm (short-circuit monitoring of the lines is active)
Detector dependence	set to 1 detector
Trigger if fault occurs	disabled
Number of detectors	Set to 1 – 10 automatic detectors

7 Programming (SETUP)

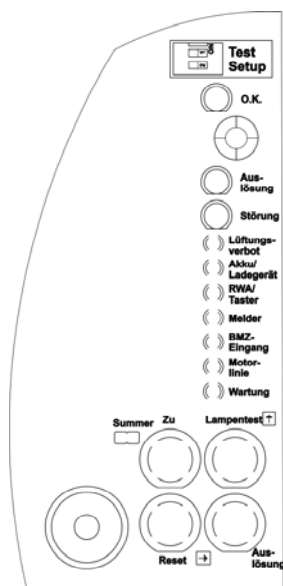
In SETUP mode, many special functions and settings can be programmed:



This is done with the „Setup“ DIP switch which if the program is to be changed, must be at ON while at the same time the „Reset “ pushbutton and the „Lamp test “ pushbutton must be set ON.

The LED „Fault“ on the board now blinks at very high frequency which indicates that Setup mode is active.



Function can be changed with 2 pushbuttons on the board and are displayed by LEDs:

The 3 large LEDs „O.K.“, „Trigger“ and „Fault“ indicate which function has been selected and the 7 small red LEDs indicate the current setting of that function.

Fig.11: Displays and control

LED	Function						
	Constant/Push	0R/18k	-- unassigned --	Detector dependent	Trigger on fault	Number of detectors	Function of the fault-relay
„O.K.“	•	•	•	☀	☀	☀	☀
„Trigger“	•	☀	☀	•	•	☀	☀
„Fault“	☀	•	☀	•	☀	•	☀
	(☀ LED blinks • LED dark)						
	Setting						
„No ventilation!“	-	-	-	-	-	-	-
„Battery“	-	-	-	-	-	-	-
„Control unit pushbutton“	-	-	-	-	All	-	-
„Detector“	-	-	-	-	Interruption	-	-
„Fire alarm input“	No ventilation	-	-	-	fire detection system	-	-
„Motor line“	OPEN/CLOSE state	-	-	2 detectors + warning	Detector	26 to 50	Alarm- relay
„Maintenance“	only pushing OPEN	0R	-	2 detectors	Control unit pushbuttons	11 to 25	Wind- and Rain- relay
(all 7 LEDs off)	Constant	18k	-	1 detector	off	1 to 10	Fault- relay

The 2 board pushbuttons „Reset “ and „Lamp test “ select the functions and change their settings:

- „Reset “ pushbutton next function (to the right)
- „Lamp test “ pushbutton Setting one position up

Any change of a position is adopted by the control unit immediately, however, to protect the changed setting(s) from the effects of a power outage, the „Setup“ DIP switch must be set OFF again. Setup mode is exited and the setting saved about 60s after the last press of a button.

8 Locating faults / troubleshooting

All faults can be detected and isolated with the aid of the diagnostic LEDs on the board. Errors that are caused by incorrect wiring of the components can, of course, not be diagnosed. If malfunctions occur which cannot be detected with the aid of the diagnostic LED's, the first step should be to verify the wiring of the external components.

If the Smoke and Heat Vent Control Unit has detected a fault, the green "Mode" LED is extinguished and the yellow "Fault" LED blinks or flashes.

Diagnostic LED display on the board	Cause	Remedy
red "Detector" LED <u>blinks</u>	Line interruption in the detector line	<ul style="list-style-type: none"> ➤ Terminate detector line with 33K resistor ➤ Investigate cable for interruption
red "Detector" LED <u>flashes</u>	Short-circuit in the detector line	<ul style="list-style-type: none"> ➤ Investigate cable for short-circuit
red "Smoke and heat vent switch" LED <u>blinks</u>	Line interruption in the smoke and heat vent switch line	<ul style="list-style-type: none"> ➤ Terminate smoke and heat vent switch line with 33K resistor ➤ Investigate cable for interruption
red "Smoke and heat vent switch" LED <u>flashes</u>	Short-circuit in the smoke and heat vent switch line	<ul style="list-style-type: none"> ➤ Investigate cable for short-circuit
red „Fire alarm center input“ LED <u>blinks</u>	Line interruption in the Fire alarm center input line	<ul style="list-style-type: none"> ➤ Terminate Fire alarm center input line with 33K resistor ➤ Investigate cable for interruption
red „Fire alarm center input“ LED <u>flashes</u>	Short-circuit in the Fire alarm center input line	<ul style="list-style-type: none"> ➤ Investigate cable for short-circuit
Red LED – Motor line <u>blinks</u>	Line interruption on motor line	<ul style="list-style-type: none"> ➤ Check SI2 motor fuses ➤ Investigate cable for short-circuit ➤ Investigate cable for interruption ➤ For third-party drives, fit 33K resistor
red "No ventilation!" LED <u>blinks</u>	Battery capacity is too low	<ul style="list-style-type: none"> ➤ Wait until battery has recharged completely
red "No ventilation!" LED <u>gives constant light</u>	Wind/rain alarm is active or fault at the wind/rain detector	<ul style="list-style-type: none"> ➤ Wait until wind/rain alarm has dropped out ➤ Check connected wind/rain detector
red "Battery/charger" LED <u>blinks</u>	Battery not connected	<ul style="list-style-type: none"> ➤ Check battery and connect if necessary
red "Battery/charger" LED <u>flashes</u>	Exhaustive discharge of battery (U < 18 V)	<ul style="list-style-type: none"> ➤ Connect new batteries !!
yellow "Fault" LED <u>flashes</u>	Power outage	<ul style="list-style-type: none"> ➤ Check 230 V AC mains voltage ➤ Check SI1 secondary fuse
red „Maintenance“ LED <u>blinks</u>	Maintenance is required	<ul style="list-style-type: none"> ➤ Inform customer service

Malfunction	Cause	Remedy
Connected automatic detectors are not triggered	Wrong polarity	<ul style="list-style-type: none"> ➤ Check polarity and connections, rectify fault
Smoke and heat vent switch malfunction	Incorrect wiring	<ul style="list-style-type: none"> ➤ Check wiring

9 Maintenance

Smoke and heat vent systems are safety systems intended to protect human lives, health, and material property.

For this reason, maintenance of the smoke and heat vent system must be carried out at regular intervals, at least once per year, in accordance with DIN 18232, the VdS directives, and the manufacturer's guidelines. Functional testing, commissioning, maintenance and any repairs on the smoke and heat vent system may only be carried out by authorised specialists

Maintenance module (optionally available):

If the optional maintenance module (slots on the board of the smoke and heat vent control unit 5A-1-1-) is installed, required maintenance is indicated by the buzzer and visually by the Fault LED at the control unit pushbutton and the Maintenance LED on the control unit board. The maintenance interval can be changed at the maintenance module.

Before carrying out work on the open control unit the technician must earth him or herself by touching the earthing connector !!!!

Caution !

You must consult with us before alarm or fault forwarding to the fire brigade or building control system by means of the integrated fire brigade relay or fault relay.

Smoke and Heat Vent Control Unit 5A-1-1:

- Visual inspection of the Smoke and Heat Vent Control Unit 5A-1-1
- Check 230 V AC mains voltage
- Check fuses SI1, SI2
- Check battery voltage (approx. 27 V DC, but not less than 24 V DC)
- After 4 years the batteries must be replaced and the old batteries disposed of
- Examine terminal connections for secure fit
- Inspect cables for possible damage
- Carry out function test (see 5 Commissioning); place "Mode" slide switch in "ON" position
- Test the functions of the Smoke and Heat Vent Control Unit by pressing all external smoke and heat vent switches, automatic detectors and ventilation pushbutton
- Test display elements of the externally connected smoke and heat vent switches and automatic detectors
- Test the fault and alarm forwarding functions; to do this, place the "Test" slide switch in the "OFF" position

10 Technical data

Type:	Smoke and Heat Vent Control Unit 5A-1-1
Housing:	Steel plate housing with cylinder lock 455 Dimensions W/H/D: 255/345/105 [mm] Colour: grey similar to RAL 9002
Protection rating:	IP 30
Temperature range:	Temperature class III according to VdS 2581 (-5°C to 40°C) Temperature class III according to VdS 2593 (-5°C to 40°C)
Rated voltage:	230V AC / 50 Hz
Rated power:	40 VA
Battery rated voltage:	24V DC (2 x 12V DC)
Battery rated capacity:	7,0 Ah or 7,2 Ah
Motor line breaking capacity:	Max. 5,0A rated current
Number of motor lines:	1
Number of ventilation groups:	1
Number of trigger groups:	1
Number of fire alarm center lines:	1
Number of smoke and heat vent pushbuttons 6, 7:	10
Number of automatic detectors	1 – 10 or 11 – 25 (see programming) (smoke detector ECO1003, maximum heat detector ECO1005T)
OPEN display output:	24V, max. 50mA
<u>Terminals:</u>	
Motor terminals:	4 mm ² (flexible), 6 mm ² (solid)
Mains connection terminals:	2.5 mm ² , plug-in type
Fault and alarm relay:	2.5 mm ²
Other terminals:	1.5 mm ² (flexible), 2.5 mm ² (solid)
Line monitoring:	Motor line for line break/fuse blow Smoke and heat vent switch line for line break and short-circuit Fore alarm system for line break and short-circuit Detector line for line break and short-circuit Battery line for line break
Trigger relay:	Breaking capacity 60V (AC/DC) / 3A Picks up when alarm occurs
Fault relay:	Breaking capacity 60V (AC/DC) / 3A Drops out when a fault occurs

Smoke and Heat Vent Control Unit 5A-1-1

Connection limits:
 Group splitting: max. 1 Smoke- and 1 Ventilation group
 Motor: max. 6 pcs. Typ JM-DC 24V in a single Ventilation group
 Smoke and Heat Vent switch: max. 10 pcs. Typ 6 and/or Typ 7
 Smoke and Heat detector: max. 25 pcs. Typ ECO 1003 or ECO 1005T (SETUP)
 Central fire alarm system input: Connection potential free contact 1NO
 Ventilation pushbutton: as many as required in 1 line (without interlocking at each other)
 Wind/rain detector: max. 8 pcs. Ventilation Switch with display open
 Output: max. 1 pcs. Typ WRM 401/C or Alternative Trigger / Fault (potentialfreie Wechslerkontakte)

24V DC motors

max. Output = 5,0A

Single- or Tandem-mode (Synchron mode)

max. 6 motors
 24V DC / 0,8A
 with LA-1 in single mode
 or
 max. 3x2 motors
 24V DC / 0,8A
 in tandem mode (synchron mode)

Schutzvermerk nach DIN 34 beachten!

1,5 mm²
 with protective conductor
 power supply
 230V 50Hz AC

display open
 U=24V DC
 I_{max}=50mA

Smoke and Heat Vent Switch

The last smoke and Heat Vent switch
 must be terminated with a 33k Ohm
 resistor.
 Max. of 10 in a single line.

power supply
 230 V~, 50 Hz

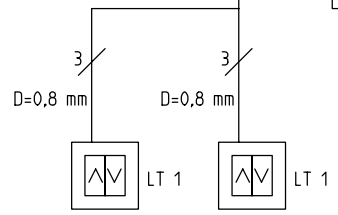
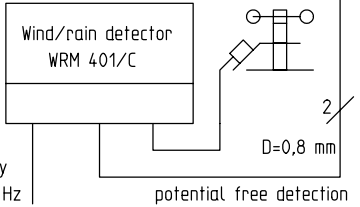

Without interlocking at each other.
 As many as required (without display open).
 8 in a single line with display open (I_{max}=50mA)

Smoke and Heat detector

The last Smoke and Heat detector must
 be terminated with a 33k Ohm resistor.

The max. amount of Smoke and Heat
 detectors can be read in the technical
 documentation.

--24_0101--0050_E001_--

vorherige Seite:							Kunde	Projektbeschreibung	Blattbeschreibung	nächste Seite: 2		
Zustand	Änderung	Datum	Name	Projekt	Datum	Name	Jofo Pneumatik GmbH	RWA-Zentrale 5A-1-1	Connection diagram	Kommission:		Anlage: =
		06.03.2006		Bearb.	16.03.2005	Krause	Eulenweg 14-20	documentation		smoke vent control unit 5A-1-1		Ort: +
				Gepr.			33758 Schloß Holte - St.			Standort	Auftragsnr.:	Blatt: 1
				Norm			Urspr.	Ers.f	Ers.d			von 7

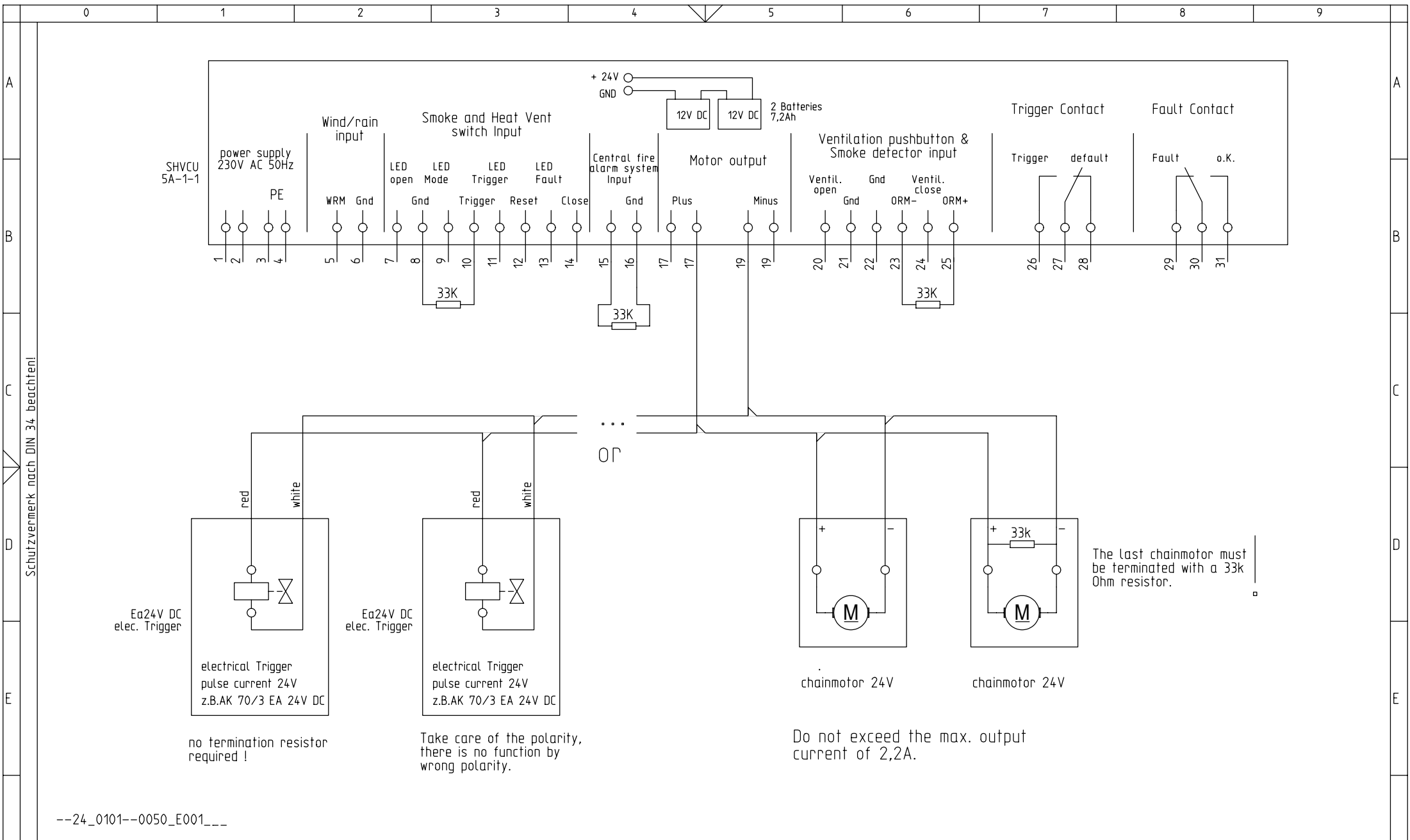

--24_0101--0050_E001_---

vorherige Seite: 2							Kunde		Projektbeschreibung		Blattbeschreibung		nächste Seite: 4			
Zustand	Aenderung	Datum	Name	Projekt	Datum	Name	Jofo Pneumatik GmbH		RWA-Zentrale 5A-1-1		Chainmotors		Kommission:		Anlage: =	
		06.03.2006		Bearb.	16.03.2005	Krause	Eulenweg 14-20		documentation		electrical triggers		smoke vent control unit 5A-1-1		Ort: +	
				Gepr.			33758 Schloß Holte - St.				Standort		Auftragsnr.:		Blatt: 3	
				Norm			Urspr.		Ers.f		Ers.d				von 7	
0	1	2	3	4	5	6	7	8	9							

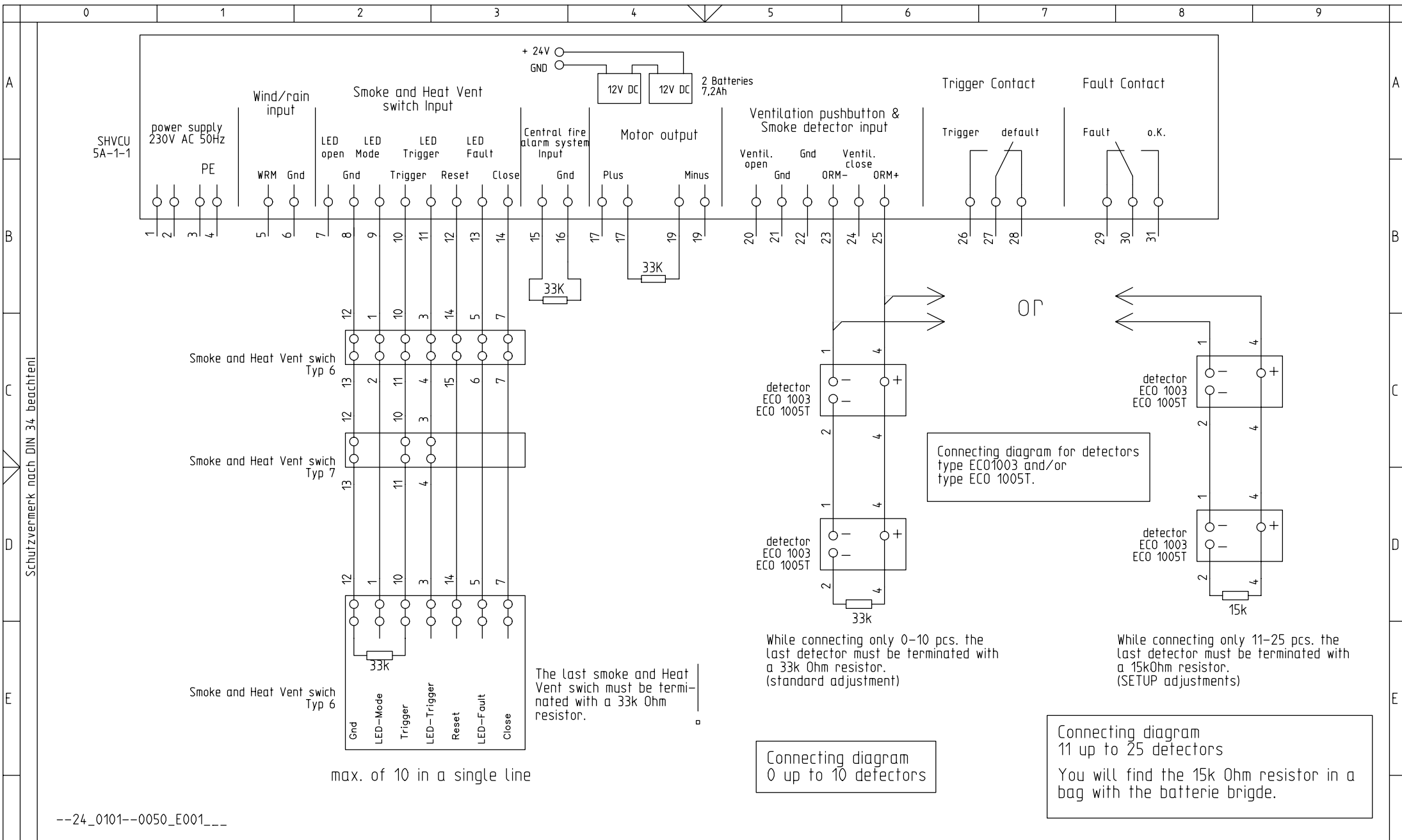

--24_0101--0050_E001_---

vorherige Seite: 3							Kunde	Projektbeschreibung	Blattbeschreibung	nächste Seite: 5		
Zustand	Anderung	Datum	Name	Projekt	Datum	Name	Jofo Pneumatik GmbH	RWA-Zentrale 5A-1-1	Smoke and Heat Vent swich	Kommission:		Anlage: =
		03.03.2006		Bearb.	16.03.2005	Krause	Eulenweg 14-20	documentation	Smoke detectors	smoke vent control unit 5A-1-1		Ort: +
				Gepr.			33758 Schloß Holte - St.		Connection diagram	Standort		Auftragsnr.:
				Norm			Urspr.	Ers.f				Blatt: 4
												von 7

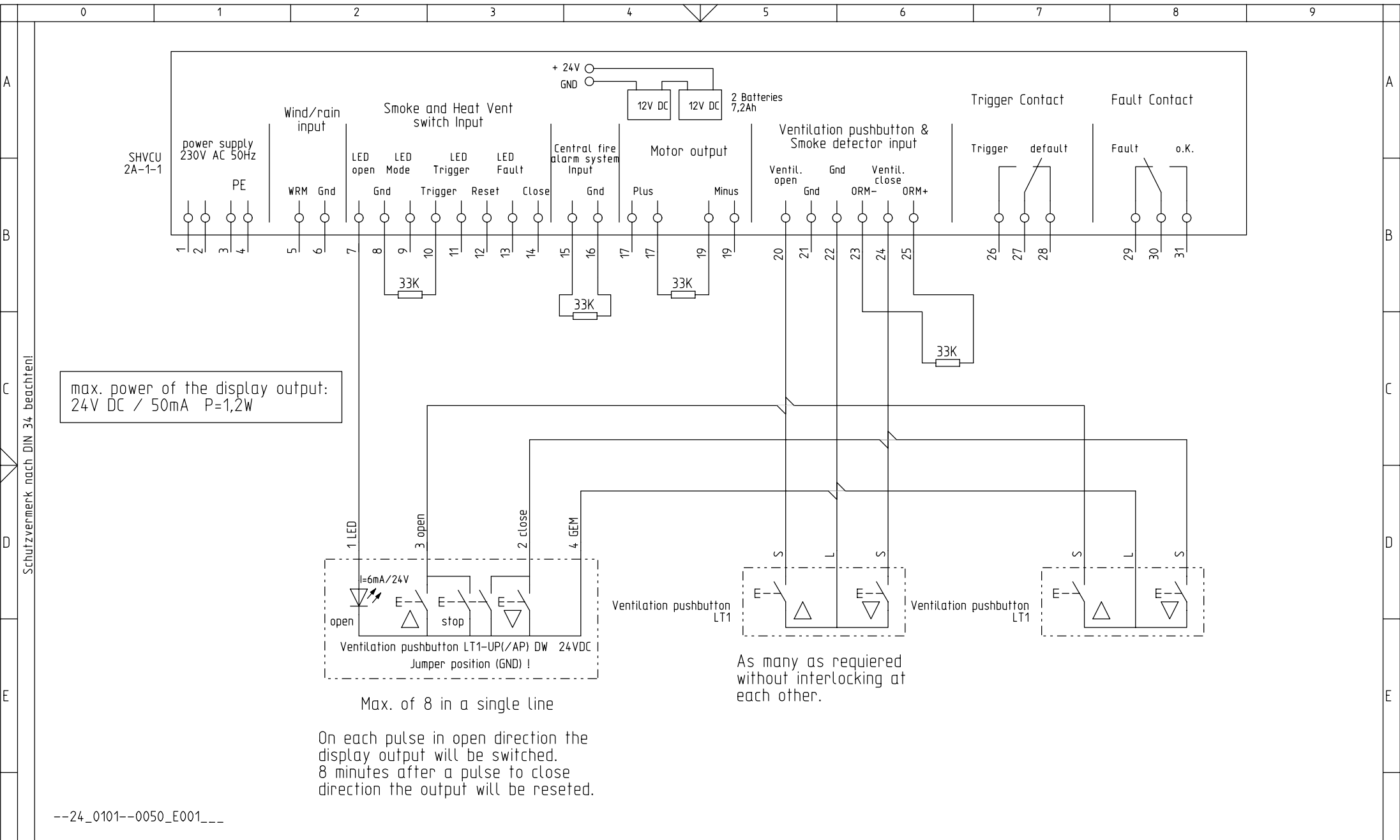

max. power of the display output:
24V DC / 50mA P=1,2W

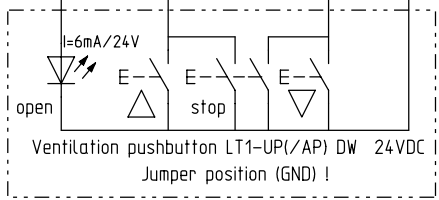

Max. of 8 in a single line

On each pulse in open direction the display output will be switched.
8 minutes after a pulse to close direction the output will be reseted.

As many as required without interlocking at each other.

--24_0101--0050_E001__

vorherige Seite: 4							Kunde		Projektbeschreibung		Blattbeschreibung		nächste Seite: 6		
Zustand	Anderung	Datum	Name	Projekt	Datum	Name	Jofo Pneumatik GmbH	RWA-Zentrale 5A-1-1 documentation		Ventilation pushbutton display open		Kommission:		Anlage: =	
		06.03.2006		Bearb.	16.03.2005	Krause	Eulenweg 14-20					Standort		Ort: +	
				Gepr.			33758 Schloß Holte - St.					Auftragsnr.:		Blatt: 5	
				Norm			Urspr.	Ers.f		Ers.d				von 7	

