

RWA K600 G - Fenster- / Türbandgegenseite
Window-/door opposite hinge side

Draufsicht: M 1:10

Gleitschiene / guide rail

Hauptmaße RWA K600 G (Gleitschiene) M 1:5
main dimensions

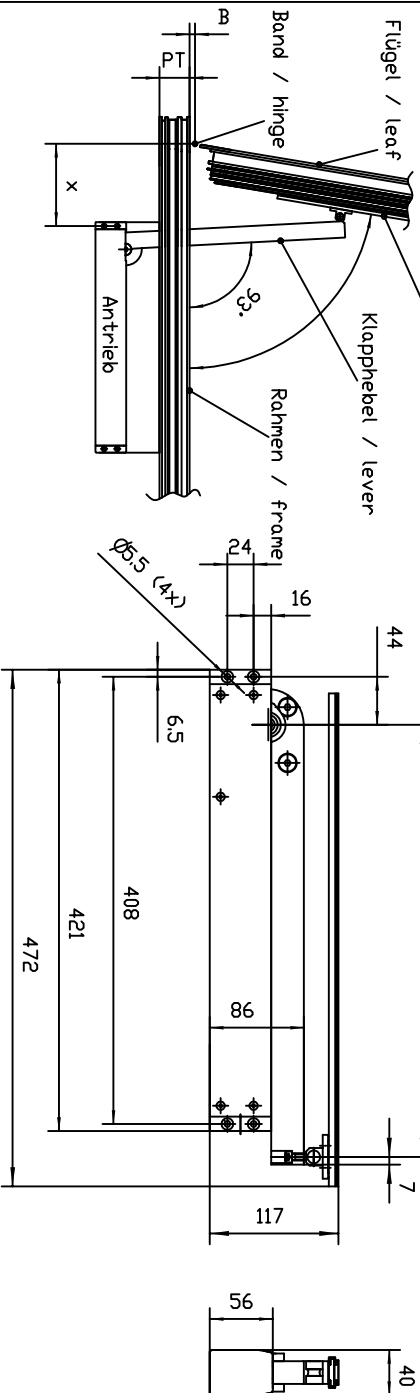

Detail Kopfpunkt: M 1:5
Befestigung Antrieb in bauseitig
vorhandenen Sturz oder
bauseitige Konsole /
Mounting of drive in lintel or
assembly bracket by customer

Montage Gleitschiene M 1:5
guide rail mounting

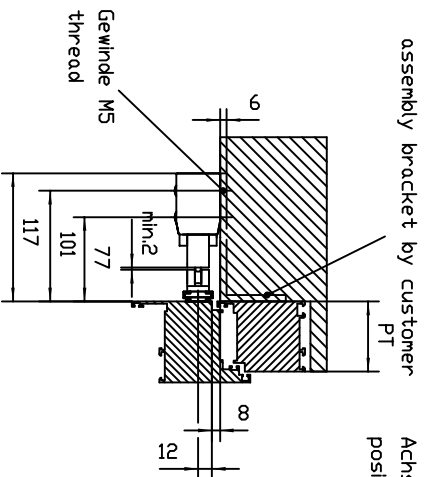

Achse Antriebsbefestigung /
position of mounting holes of drive

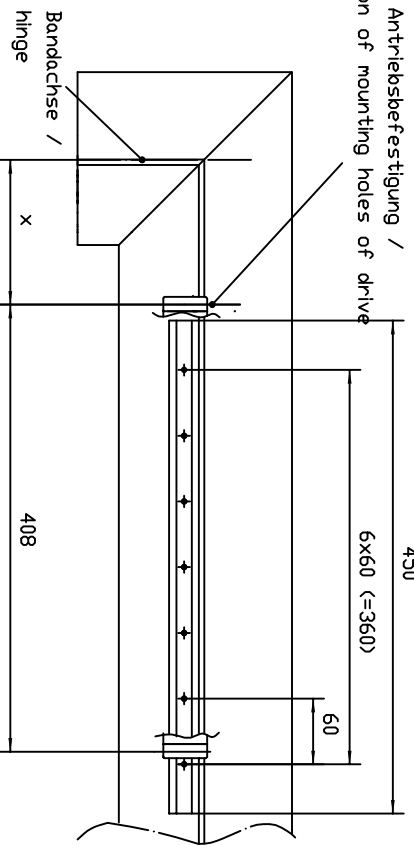

x = Abstand des Fensterbandes zur Antriebsbefestigung /
distance hinge to mounting holes of drive
PT = Profiltiefe des Blendrahmens / profile depth of frame
B = Bandachsmass / hinge distance

Zusammenbau Gleiter
assembly glider

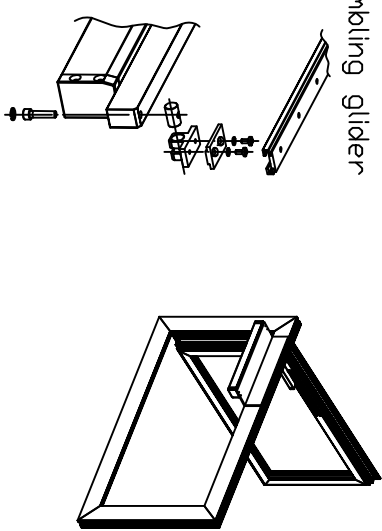

Öffnungswinkel in Abhängigkeit vom x-Maß,
vom Bandachsmass (PT) und der Profiltiefe des
Blendrahmens (PT)
opening angle in dependency of dimension x,
hinge distance and profile depth of frame [PT]

Bandachsmass 213mm hinge distance 213mm
Bandachsmass 222mm hinge distance 222mm
Bandachsmass 236mm hinge distance 236mm

x (mm)	Profile depth frame (mm)	x (mm)	Profile depth frame (mm)	x (mm)	Profile depth frame (mm)
95	94*	95	94*	95	94*
100	93*	100	93*	100	93*
110	92*	110	92*	110	92*
120	88*	120	90*	120	94*
130	86*	130	88*	130	91*
140	84*	140	86*	140	89*
150	82*	150	84*	150	87*
160	80*	160	81*	160	84*
170	78*	170	79*	170	82*
180	76*	180	77*	180	80*
190	74*	190	75*	190	78*
200	72*	200	73*	200	76*
225	68*	225	69*	225	71*
250	64*	250	65*	250	66*
275	60*	275	61*	275	62*
300	57*	300	57*	300	58*
325	54*	325	54*	325	55*
350	51*	350	51*	350	52*

abweichende Profiltiefen und Bandachsmasse auf Anfrage!
different hinge distances on inquiry!

05	2806.16	16F3	*		
04	0805.12	16F4	*		
03	2803.12	16F6	*		
02	0909.10	16F9	*		
01	1806.09	16F9	*		
00	0704.09	16F9	*		

EMPB = Erstuntersuchungsbericht / First sample test report

GEZE GmbH
RWA K600 G
Klapphebelantrieb RWA K600 G n. aussen
Retractable arm drive RWA K600 G outward (I)

Bestell- / order no. 2806.16
Name sheet / of 1 / 2
Material-Nr. 45160-EP-004

Erstellt / drawn 2806.16
Frg. Prod./del. Prod. 30.08.16
Scale 1:1
Sprache / language
Zeichnungs-Nr. / document no. 45160-EP-004