

**Order designation:** TAG 690 - VV - 42 - thread for bottle connection  
**Example:** TAG 690 - VV - 42 - M 10 x 1

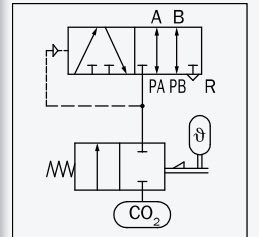
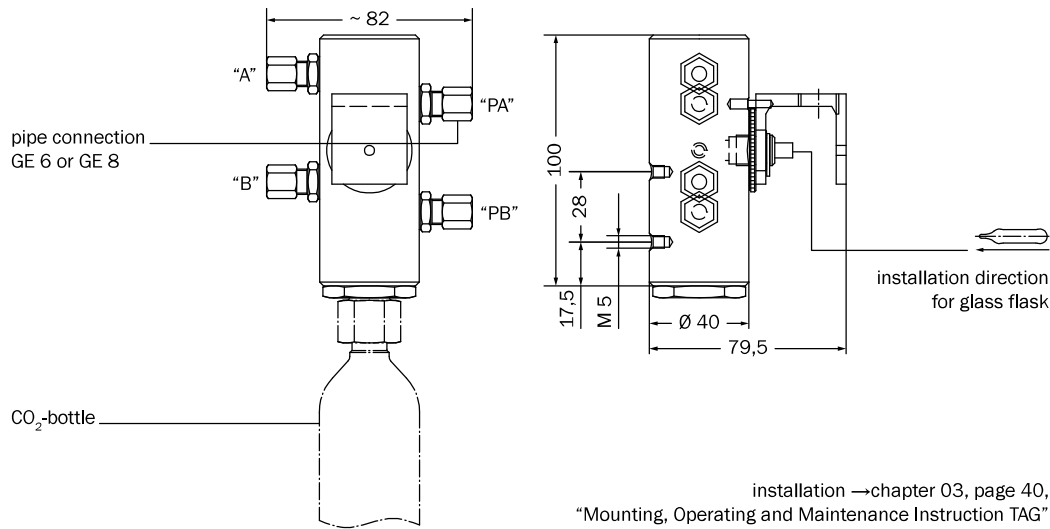

After the installation of the fire detection element (glass bulbs  $\varnothing$  5 mm) the energy source (CO<sub>2</sub>-bottle) is activated and the pressure released after the connection "A". The connection "B" is vented. The network power connections "PA" and "PB" are blocked.

## Short description

→chapter 03, page 41, "Mounting, Operating and Maintenance Instructions TAG"

## Operation

medium	CO <sub>2</sub> compressed air
max. allowed operating pressure	60 bar
test pressure	90 bar
environmental class	according to VdS 2584 Environmental class III, -25 °C to +110 °C
materials	aluminum, niro, brass, steel galvanized, sealings Perbunan
maintenance	once a year (→chapter 03, page 41, "Mounting, Operating and Maintenance Instructions TAG")
VdS-approval number	G 592015
ambient temperature	-25 °C to +60 °C

## Technical data

The VdS-permission is only valid in connection with the tested glass bulbs and CO<sub>2</sub>-bottles.

Glass bulbs	CO <sub>2</sub> -bottles wit thread	Tension screw
68° red	▶ W 21,8x1/14	▶ W 21,8 x 1/14
93° green	▶ M 20x1,5	▶ 1/2" - 20 UNF-1A
141° blue (not VdS)	▶ 1/2" - 20 UNF-1A	▶ M 18 x 1,5
182° mallow (not VdS)	▶ M 18x1,5	▶ M 15 x 1,25
others upon request (not VdS)	▶ M 15x1,25	▶ M 10 x 1
	▶ M 10x1	

## Accessories

### Additional equipment (only order with DE-bracket)

pneumatic release cylinder (PA 4)	→chapter 03, page 39, "Additional Equipment TAG"
pneumatic release cylinder with pressure stage 10 bar (PA 10)	→chapter 03, page 39, "Additional Equipment TAG"
electric actuation TM	→chapter 03, page 39, "Additional Equipment TAG"
pressurized gas-actuation (pyrotechnic) DE	→chapter 03, page 39, "Additional Equipment TAG"
electric signal contact EMK	→chapter 03, page 39, "Additional Equipment TAG"

### Holder

fastening rail TAG 40 / 41 / 42 / 43	→chapter 6.2, page 234, "Fastening Rail for TAG"
holder TAG 40 / 41 / 42 / 43	→chapter 6.2, page 235, "Holder for TAG"