

PRIMAT-E kompakt 300 230 V AC

PRIMAT-S kompakt 300 24 V DC

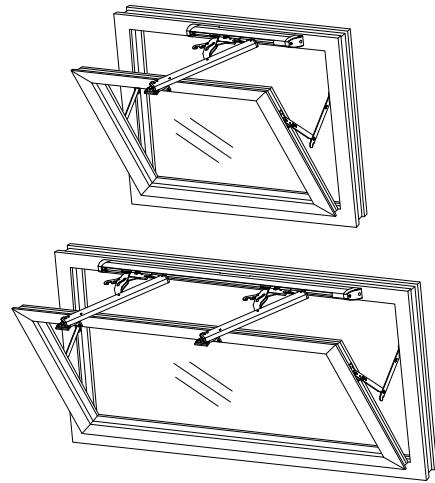

Profilschnitte Profil section

rechtwinklige Fenster
rectangular window

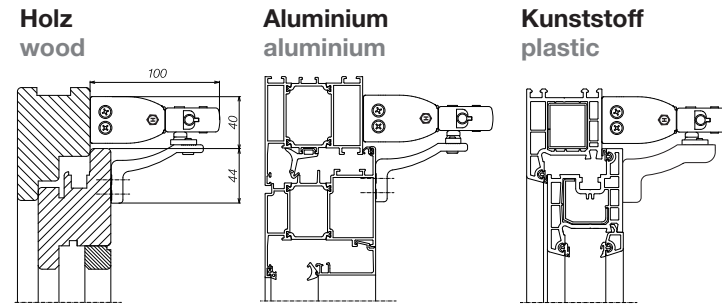

Fenster mit oberer Schräge
top sloping window

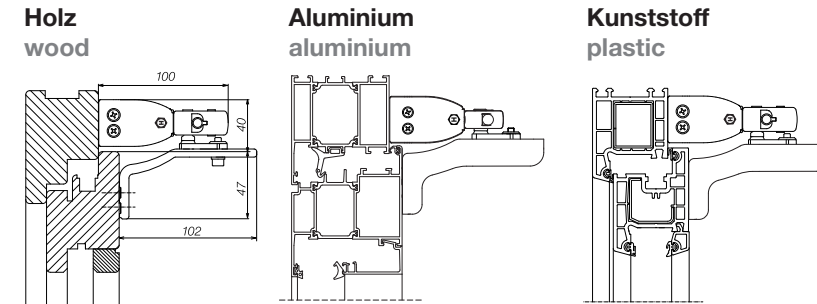

Einsatzbereich Application area	1-scherig 1-stay	2-scherig 2-stay
FH min.	550 mm	550 mm
FB min. ohne/without ZV/F	500 mm	1200 mm
FB max. ohne/without ZV/F	1450 mm	2400 mm
FB min. mit/with ZV/F	720 mm	1200 mm
FB max. mit/with ZV/F	1600 mm	2800 mm

Anwendungsbereiche Application areas

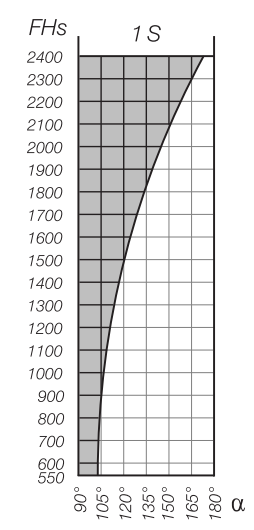
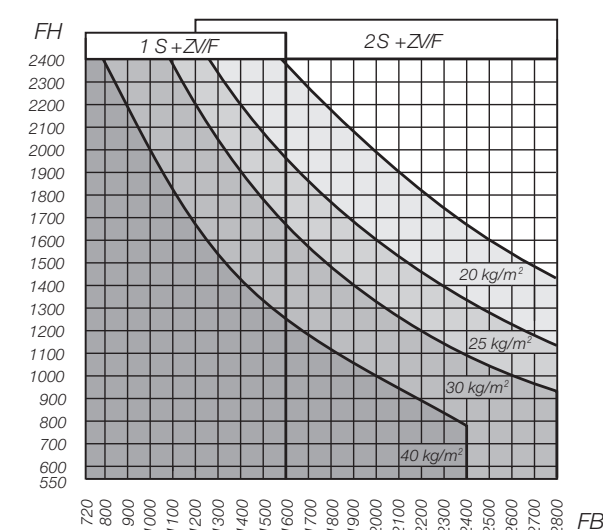
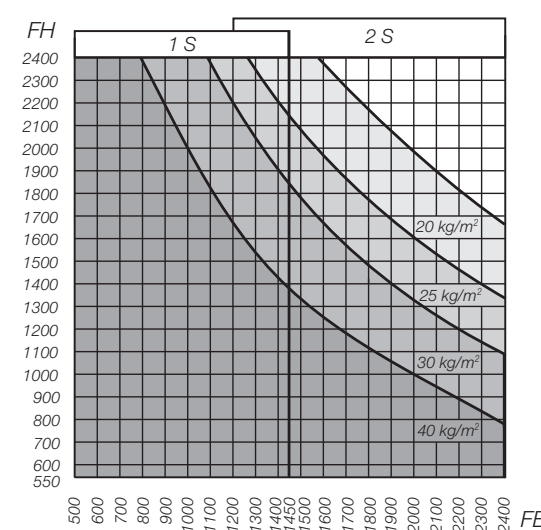
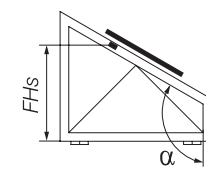
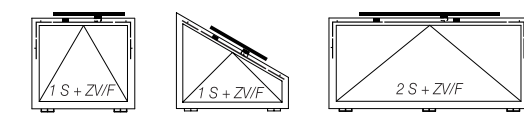
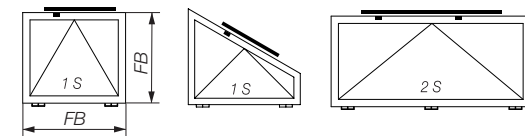

max. Flügelgewicht 80 kg
max. sash weight

max. Glasgewicht 40 kg/m²
max. glas weight

Alle Anwendungsdiagramme gelten nur unter nachfolgenden Bedingungen
All application charts are subject to the following conditions

Keine Zusatzlasten an den Flügel anbringen
No additional encumbrances

Keine Windlasten
No wind load

Alle Maße in [mm]
All units in millimeters [mm]